

# BIKE PART SUPER SORT

**Skills:** Locomotor Travel, General Knowledge of Bicycle Parts, Teamwork, Cooperation

**Fitness Target:** Aerobic Capacity, Muscular Endurance, Muscular Strength

**Virginia Standards:** Health - K.1j, 1.1e, 1.2i, 2.2e, 3.1e, 3.2h, 4.2i, 5.2f  
PE - K.1a&f, K.4a&b, 1.1a&h, 1.3b, 1.4c, 2.1d&e, 2.3d, 2.4c, 3.2a, 3.3d, 3.4c, 4.1a, 4.3, 4.4a, 5.1.a

**National Standards:** Physical Education Standard S1.E1.K-4, S1.E2.2a, S2.E1.Ka, S2.E1.1-3, S2.E1.4a

**Equipment:** Cones to mark the playing area, polypots to mark "home" for each pair of students, Bike Parts Task Cards

**Activity:**  
 Before the activity begins, the teacher will discuss or review the basic parts of a bike with the class (see attached diagram).

Primary Grades (K-2)	Intermediate Grades (3-5)
Frame	Top Tube
Wheels	Down Tube
Saddle	Seat Tube
Tire	Head Tube
Spokes	Seat Post
Handle Bar	Seat Stay
Grips	Chain Stay
Pedal	Cassette
Wheel	Chain Rings
Brake	Pedal
Chain	Crank
	Tire
	Fork
	Saddle
	Brake
	Brake Lever
	Rim
	Spokes

## BIKE PART SUPER SORT

After the review or discussion, students will find a partner and stand behind a polyspot on one end of the playing area. On the other end of the playing area, the teacher will place the bike part task cards (see the attached task card list). Each pair of students will receive a Bike Label Task Sheet.

When the activity begins, one of the two partners will travel across the playing area and collect one bike part task card. When the partner returns, he/she will place the bike part in the correct location using the Bike Label Task Sheet. The new partner will then repeat the task collecting a new bike part. The task will continue until all of the bike parts have been collected and placed in the correct order. When the task is complete, the pair will raise their hands and the teacher will check the progress of the students. If the students were able to complete the task correctly, they can replace their cards and attempt the activity again using a more challenging Bike Label Task Sheet or travel using a different locomotor pattern while completing the task again.

### Teaching Tips:

- Have students travel in a different locomotor pattern each time they travel to collect a task card during the activity.
  - Increase physical activity by having the waiting partner perform a fitness task while they wait.
  - Integrate sports skills while partners are waiting (i.e., – basketball dribble, soccer juggle, toss and catch with a ball, etc.).
  - Provide students with a Bike Part Key when they have completed the task to check their work.
  - If students are making common errors during the activity, take time to provide feedback to correct the issue.
  - Use a visual to help students learn the parts of the bike (i.e., – label a real bike or a poster size version of the Bike Part Key)
-

## BIKE PART SUPER SORT

# FRAME

Primary

# WHEEL

Primary

# HANDLEBAR

Primary

# SADDLE

Primary

# TIRE

Primary

# SPOKES

Primary

## BIKE PART SUPER SORT

# GRIPS

Primary

# PEDAL

Primary

# CHAIN

Primary

# BRAKE

Primary

# SEAT POST

Intermediate

# FORK

Intermediate

## BIKE PART SUPER SORT

# HANDLEBAR

Intermediate

# SADDLE

Intermediate

# TIRE

Intermediate

# SPOKES

Intermediate

# GRIPS

Intermediate

# PEDAL

Intermediate

## BIKE PART SUPER SORT

# WHEEL

Intermediate

# BRAKE

Intermediate

# BRAKE LEVER

Intermediate

# TOP TUBE

Intermediate

# DOWN TUBE

Intermediate

# HEAD TUBE

Intermediate

## BIKE PART SUPER SORT

# SEAT TUBE

Intermediate

# CHAIN STAY

Intermediate

# SEAT STAY

Intermediate

# REAR DERAILLEUR

Intermediate

# FRONT DERAILLEUR

Intermediate

# RIM

Intermediate

## BIKE PART SUPER SORT

# CHAIN RINGS

Intermediate

# CASSETTE

Intermediate

# CRANK

Intermediate



**BIKE PART SUPER SORT**

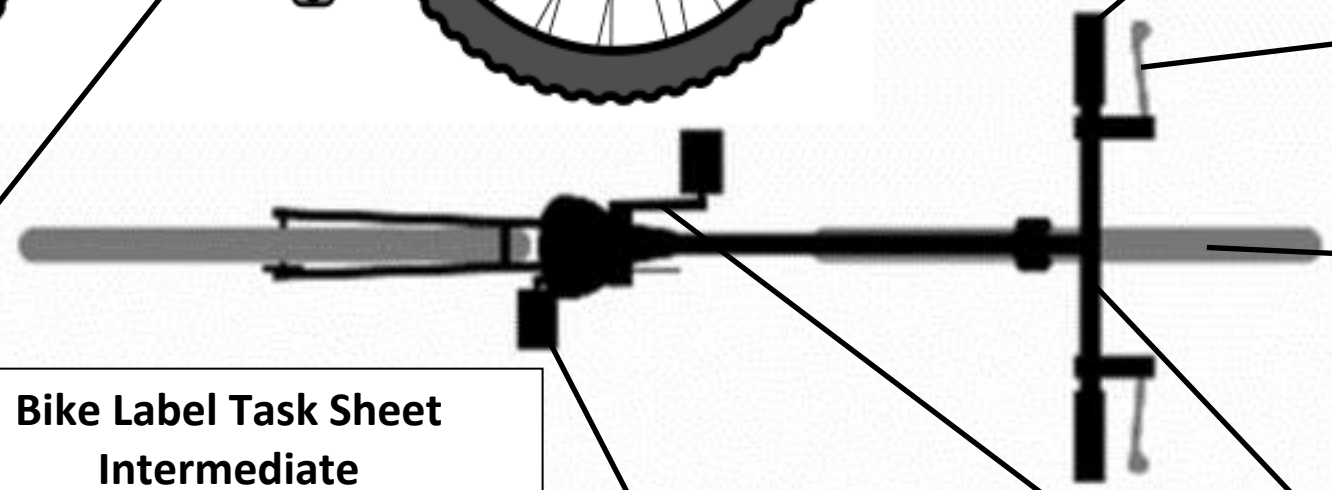

**Bike Label Task Sheet Intermediate**

# BIKE PART SUPER SORT

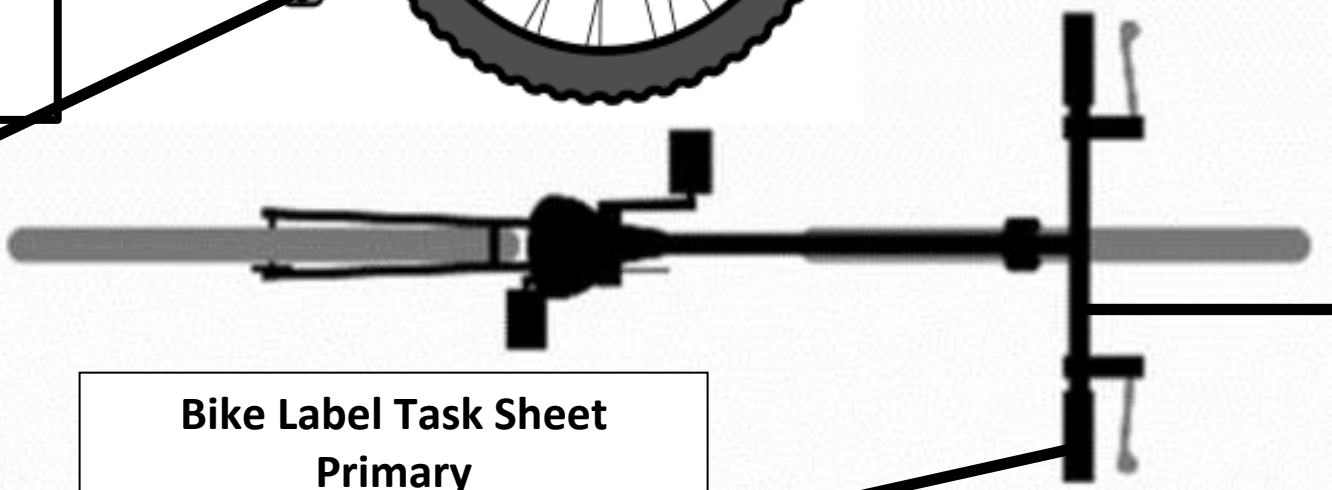

**Bike Label Task Sheet  
Primary**