

**INSTRUCTIONAL GUIDE TO
SUPPORT 2023 GRADE 8
MATHEMATICS *STANDARDS
OF LEARNING***



Copyright © 2025
by the
Virginia Department of Education
P.O. Box 2120
Richmond, Virginia 23218-2120
<http://www.doe.virginia.gov>

All rights reserved. Reproduction of these materials for instructional purposes in public school classrooms in Virginia is permitted.

Superintendent of Public Instruction

Emily Anne Gullickson, M.Ed. J.D.

Office of Math and Science

Dr. Anne Petersen, Director of Math and Science
Dr. Angela Byrd-Wright, Director of Humanities (Former Mathematics Coordinator)
Ms. Victoria Bohidar, Mathematics Coordinator
Dr. Jessica Brown, Elementary Mathematics Specialist
Dr. Regina Mitchell, Mathematics and Special Education Specialist
Mrs. Donna Snyder, Mathematics Division Support Specialist

NOTICE

The Virginia Department of Education does not unlawfully discriminate on the basis of race, color, sex, national origin, age, or disability in employment or in its educational programs or services.

Table of Contents

Introduction	3
Understanding the Standard.....	3
Skills in Practice.....	3
Concepts and Connections	3
Number and Number Sense	4
8.NS.1.....	4
8.NS.2.....	11
Computation and Estimation	15
8.CE.1.....	15
Measurement and Geometry	23
8.MG.1.....	23
8.MG.2.....	30
8.MG.3.....	39
8.MG.4.....	45
8.MG.5.....	52
Probability and Statistics	59
8.PS.1.....	59
8.PS.2.....	66
8.PS.3.....	74
Patterns, Functions, and Algebra	79
8.PFA.1.....	79
8.PFA.2.....	86

8.PFA.3	92
8.PFA.4	101
8.PFA.5	108

Introduction

The Mathematics Instructional Guide, a companion document to the 2023 Mathematics *Standards of Learning*, amplifies the Standards of Learning by defining the core knowledge and skills in practice, supporting teachers and their instruction, and serving to transition classroom instruction from the 2016 *Mathematics Standards of Learning* to the newly adopted 2023 *Mathematics Standards of Learning*. Instructional supports are accessible in #GoOpenVA and support the decisions local school divisions must make concerning local curriculum development and how best to help students meet the goals of the standards. The local curriculum should include a variety of information sources, readings, learning experiences, and forms of assessment selected at the local level to create a rigorous instructional program.

For a complete list of the changes by standard, the [2023 Virginia Mathematics Standards of Learning – Overview of Revisions](#) is available and delineates in greater specificity the changes for each grade level and course.

The Instructional Guide is divided into three sections: Understanding the Standard, Skills in Practice, and Concepts and Connections aligned to the Standard. The purpose of each is explained below.

Understanding the Standard

This section includes mathematics understandings and key concepts that assist teachers in planning standards-focused instruction. The statements may provide definitions, explanations, or examples regarding information sources that support the content. They describe what students should know (core knowledge) as a result of the instruction specific to the course/grade level and include evidence-based practices to approaching the Standard. There are also possible misconceptions and common student errors for each standard to help teachers plan their instruction.

Skills in Practice

This section outlines supporting questions and skills that are specifically linked to the standard. They frame student inquiry, promote critical thinking, and assist in learning transfer. Curriculum writers and teachers should use them to plan instruction to deepen understanding of the broader unit and course objectives. This is not meant to be an exhaustive list of student expectations.

Concepts and Connections

This section outlines concepts that transcend grade levels and thread through the K through 12 mathematics program as appropriate at each level. Concept connections reflect connections to prior grade-level concepts as content and practices build within the discipline as well as potential connections across disciplines.

Grade 8

Number and Number Sense

In K-12 mathematics, numbers and number sense form the foundation building blocks for mathematics understanding. Students develop a foundational understanding of numbers, their properties, and the relationships between them as they learn to compare and order numbers, understand place value, and perform numerical operations. Number sense includes an understanding of patterns and the relationships between numbers and being able to apply this knowledge to real world problems. Throughout K-12, students build on their number sense to develop a deeper understanding of mathematical concepts and reasoning.

In Grade 8, students use multiple representations of numbers and relationships among numbers that provide meaning and structure to allow for sense-making. At this grade level, students compare and order real numbers, determine relationships between real numbers, and investigate and describe the relationship between the subsets of the real number system.

8.NS.1

The student will compare and order real numbers and determine the relationships between real numbers.

Students will demonstrate the following Knowledge and Skills:

- a) Estimate and identify the two consecutive natural numbers between which the positive square root of a given number lies and justify which natural number is the better approximation. Numbers are limited to natural numbers from 1 to 400.
- b) Use rational approximations (to the nearest hundredth) of irrational numbers to compare, order, and locate values on a number line. Radicals may include both positive and negative square roots of values from 0 to 400 yielding an irrational number.
- c) Use multiple strategies (e.g., benchmarks, number line, equivalency) to compare and order no more than five real numbers expressed as integers, fractions (proper or improper), decimals, mixed numbers, percents, numbers written in scientific notation, radicals, and π . Radicals may include both positive and negative square roots of values from 0 to 400. Ordering may be in ascending or descending order. Justify solutions orally, in writing or with a model.

Understanding the Standard

- A perfect square is a whole number whose square root is an integer.
- The square root of a given number is any number which, when multiplied by itself, equals the given number.
- Squaring a number and taking a square root of a number are inverse operations.

$$-\sqrt{36} = -6$$

$$(-6)^2 = -6 \cdot -6 = 36$$

- Both the positive and negative roots of whole numbers, except zero, can be determined. The square root of zero is zero. The value is neither positive nor negative. Zero (a whole number) is a perfect square.
- The positive and negative square root of any whole number other than a perfect square lies between two consecutive integers (e.g., $\sqrt{57}$ lies between 7 and 8 since $7^2 = 49$ and $8^2 = 64$; $-\sqrt{11}$ lies between -4 and -3 since $(-4)^2 = 16$ and $(-3)^2 = 9$, and 11 lies between 9 and 16).
- The symbol $\sqrt{\quad}$ may be used to represent a positive (principal) root and $-\sqrt{\quad}$ may be used to represent a negative root.
- The square root of a whole number that is not a perfect square is an irrational number (e.g., $\sqrt{2}$ is an irrational number). An irrational number cannot be expressed exactly as a fraction $\frac{a}{b}$ where $b \neq 0$.
- Square root symbols may be used to represent solutions to equations of the form $x^2 = p$. Examples may include:
 - If $x^2 = 36$, then x is $\sqrt{36} = 6$ or $-\sqrt{36} = -6$.
 - If $x^2 = 5$, then x is $\sqrt{5}$ or $-\sqrt{5}$.
- Grid paper and estimation can be used to determine what is needed to build a perfect square. The square root of a positive number can be defined as the side length of a square with an area equal to the given number. If it is not a perfect square, the area provides a means for estimation.
- Real numbers can be represented as integers, fractions (proper or improper), decimals, percents, numbers written in scientific notation, radicals, and π . Methods for comparing and ordering include using benchmarks, models, number lines, and conversion to one representation.

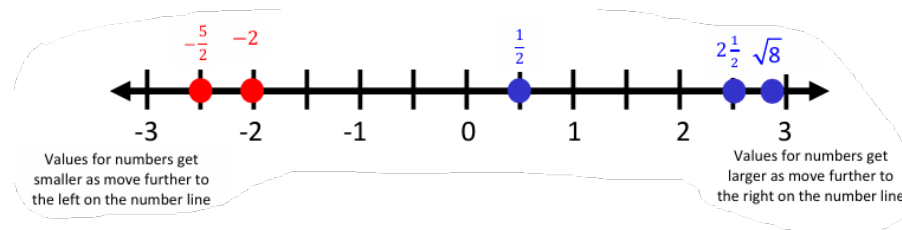

- Proper fractions, improper fractions, and mixed numbers are terms often used to describe fractions. A proper fraction is a fraction whose numerator is less than the denominator. An improper fraction is a fraction whose numerator is equal to or greater than the denominator (equal to or greater than the integer 1). An improper fraction may be expressed as a mixed number. A mixed number is written with two parts: a whole number and a proper fraction (e.g., $3\frac{5}{8}$). Fractions can have a positive or negative value.

- The density property states that between any two real numbers lies another real number. For example, between 3 and 5, the number 4 can be found; between 4.0 and 4.2, the number 4.16 can be found; between 4.16 and 4.17, the number 4.165 can be found; between 4.165 and 4.166, the number 4.1655 can be found, etc. Thus, there is always another number between any two numbers. Students are not expected to know the term *density property*, but the concept allows for a deeper understanding of the set of real numbers.

Skills in Practice

While the five process goals are expected to be embedded in each standard, the Skills in Practice highlight the most prevalent process goals in relation to the content presented.

Mathematical Reasoning: Students must justify their solutions through writing, speaking, symbols, and models. Suppose a student was asked to determine whether the given statement is true or false and provide justification of the following –

$$1.\bar{4} > \frac{7}{5}$$

The student responds, “*This statement is false because 1.4 is equal to $\frac{7}{5}$. This is because the improper fraction converted to a decimal is equal to 1.4. I solved this by dividing 7 by 5 and it is equal to 1.4.*” A common error the student made here is assuming this statement is false because they ignored the repeating symbol and thought the two values were equal. This misconception may indicate that a student has not yet developed an understanding of comparing decimal numbers expressed as terminating or repeating decimals. Real numbers can be represented as integers, fractions (proper or improper), decimals, percents, numbers written in scientific notation, radicals, and π .

Mathematical Communication: Students must be given opportunities to communicate their understanding of this standard through writing, speaking, symbols, and models. Care must be taken to demonstrate these various forms of communication so that students may replicate various models through *mathematically accurate computation* and *derivation* of appropriate solutions. For example, have students explain to each other how to order and compare real numbers. Students should use the appropriate vocabulary (ascending or descending order) when ordering and comparing real numbers.

- Students may justify ordering real numbers using benchmarks. Suppose a student was asked to place the following real numbers in ascending order:

$$\frac{7}{5}, \sqrt{8}, -2$$

The student may respond, “*I used the benchmarks 0, $1\frac{1}{2}$, 2 and 3 when ordering these numbers. $\frac{7}{5}$ is equal to $1\frac{2}{5}$ so I know that is a little less than $1\frac{1}{2}$. I know -2 is less than zero and the square root of 8 will be between 2 and 3. The numbers in ascending order would be $-2, \frac{7}{5}, \sqrt{8}$.*”

Mathematical Representations:

- As students estimate and identify the two consecutive natural numbers between which the positive square root of a given number lies, engage in discussions per the example below –
 - Ask students to discuss and define a perfect square. Have students provide examples of perfect squares.
 - Write $\sqrt{49}$ on the board. Ask students to identify the square root. Students should respond with 7. Then, write $\sqrt{64}$ on the board. Ask students to identify the square root. Students should respond with 8. Ask students a few more known perfect squares, alternating between negative square roots and positive square roots.
 - Now, write $\sqrt{52}$ on the board. Discuss with students how they can use their knowledge of perfect squares to estimate where this square root would fall on a number line. Guide the discussion to help students to understand that the square root of 52 falls between 7 and 8; therefore, the square root of 52 must fall between the square roots of 49 and 64.
 - Model this understanding using a number line. As students use number lines to model results of other practice problems, expect students to justify which natural number is the better approximation.
- When approximating the location of irrational numbers on a number line, for example, the $\sqrt{43}$, first identify the closest perfect square roots above and below the given number. In this example, the closest perfect square roots are 36 (less than 43) and 49 (greater than 43). Write as an inequality, $\sqrt{36} < \sqrt{43} < \sqrt{49}$. Take the square root of the perfect squares, $6 < \sqrt{43} < 7$. A general estimate is that 43 is between 6 and 7. Narrow the estimate, using the following standard algorithm: $\sqrt{a} \frac{b-a}{c-a}$. Per the example, the result is $\sqrt{36} \frac{43-36}{49-36}$. Simplify the expression to $6 \frac{7}{13}$, which is approximately 6.54 when rounded to the nearest hundredth. Use a number line to identify the location on the number line (the square root of 43 would be located near $6 \frac{1}{2}$ on a number line).

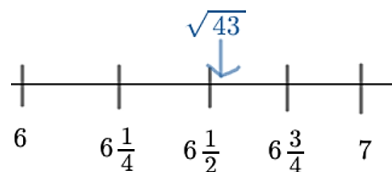

- Students may be presented with problems in context that provide opportunities to estimate and identify two consecutive natural numbers between which the positive square root of a given number lies. Problems should include opportunities for students to justify their answers. An example is provided to include a description of a common misconception –

A square has an area of 200 square feet. Between what two consecutive integers would the length of each side fall? Justify your answer.

A common error students may make is dividing 200 by 4 instead of taking the square root of 200. This may indicate students have a misconception between area and perimeter. They may need more practice with the relationship between the area of a square and the length of its sides. Teachers may consider using area models with perfect square areas and lead into area models with non-perfect square areas to explore the relationship between area of a square and the length of its sides.

- Methods for comparing and ordering include using benchmarks, models, number lines, and conversion to one representation. Students must use multiple strategies to include benchmarks, number lines, and application of standard algorithms to recognize equivalence and when comparing and ordering real numbers. For example, if students were asked to order the given numbers in ascending order –

$$-1.25, -\frac{3}{10}, -1\frac{2}{5}, -0.03, -\sqrt{2}$$

A common misconception that students may have is believing that $-\sqrt{2}$ has the greatest value because it has the largest absolute value and/or the student is treating the numbers as if they are all positive. This may indicate a need to revisit representing, ordering, and comparing integers (6.NS.2) and rational numbers (7.NS.1).

- Another strategy is to use a place value chart to ensure that students align the numbers by the appropriate place value to compare them and order them properly. With grid paper, this can be done by stacking each value in different rows and aligning the decimal points on one vertical line.

Mathematical Connections:

- In Grade 7, students determined the *positive square root* of a perfect square from 0 to 400. This is understood to be the *principal square root*. This understanding should be connected and extended at Grade 8, where students learn that both the positive and negative roots of whole numbers, except zero, can be determined. The symbol \pm means both the positive and negative of the number or variable given.
 - Negative numbers can be squared. When a negative number is squared the result is a positive number. This is because a negative number multiplied by a negative number yields a positive result. For example –
 - $(-5)(-5) = 25$, therefore, $(-5)^2 = 25$
 - $(-7)(-7) = 49$, therefore, $(-7)^2 = 49$
 - The concept above is true for all numbers and variables. For example –
 - $(4)^2$ and $(-4)^2$ both equal 16
 - $(x)^2$ and $(-x)^2$ both equal x^2

- A square root of a number is a number which, when multiplied by itself, produces the given number. To develop students' understanding of this concept, provide them with values such as 0, 50, 125, 200, and 361. Ask them to determine whether the values are perfect squares and provide a justification with their response. A common misconception students may have from the given values is assuming that even numbers are perfect squares because they can be divided by 2 to get a whole number. The values of 50 and 200, when divided by two, provide students with whole numbers.
- Students may make the error of adding a number to itself to get the perfect square value instead of multiplying it by itself. Teachers should emphasize a square root is a *repeated factor* of the perfect square, not a *repeated addend*. For example, 289 is a perfect square since $\sqrt{289} = \sqrt{17 \cdot 17}$ or $17^2 = 17 \cdot 17 = 289$. This shows the student the repeated factor of 17. Graph paper or an area model can be used to illustrate perfect squares, giving students a concrete and pictorial representation of these concepts. Creating opportunities such as these allow students to recognize that squaring a number and taking a square root of a number are inverse operations.

Concepts and Connections

CONCEPTS

There are multiple representations of numbers and relationships among numbers that provide meaning and structure and allow for sense-making.

CONNECTIONS

- *Within the grade level/course:*
 - 8.NS.2 – The student will investigate and describe the relationship between the subsets of the real number system.
 - 8.MG.4 – The student will apply the Pythagorean Theorem to solve problems involving right triangles, including those in context.
- *Vertical Progression:*
 - 7.NS.1 – The student will investigate and describe the concept of exponents for powers of ten and compare and order numbers greater than zero written in scientific notation.
 - 7.NS.2 – The student will reason and use multiple strategies to compare and order rational numbers.
 - A.EO.3 – The student will derive and apply the laws of exponents.
 - A.EO.4 – The student will simplify and determine equivalent radical expressions involving square roots of whole numbers and cube roots of integers.

ACROSS CONTENT AREAS [THEME – NUMBERS, NUMBER SENSE, AND PATTERNS]

- *Computer Science:*

- Patterns and Sequence concepts include recognizing patterns in data structures and algorithms; using loops to repeat patterns; and designing algorithms that follow step by step sequence.
- Variables and Expressions concepts include declaring and assigning values to variables and using variables in functions, conditionals, loops.
- Problem Solving/Algorithmic Thinking concepts include designing algorithms to solve computational problems; decomposition (CT); and pseudocode.
- Algebraic Thinking highlights include variables and expressions in programming – algebraic expressions are fundamental in coding, defining functions, and manipulating data; conditional statements and Boolean logic – logical operations in programming and database queries; control flow – decision making and loop programming constructs use algebraic conditions; and recursion and iteration in algorithms – recursive functions rely on algebraic expressions to define their base cases and recursive steps.
- Number Systems highlights include binary, octal, and hexadecimal representations – computer store and process data using different number bases; data storage and memory representation – data type storage; and floating-point arithmetic and precision errors – understanding floating point numbers.
- *Physical Science:*
 - PS.3 The student will investigate and understand that matter has properties and is conserved in chemical and physical processes. To meet this standard, students are expected to balance chemical equations and distinguish between endothermic and exothermic reactions.
 - PS.4 The student will investigate and understand that the periodic table is a model used to organize elements based on their atomic structure. To meet this standard, students are expected to describe and explain patterns in the periodic table.
 - PS.8 The student will investigate and understand that work, force, and motion are related. To meet this standard, students are expected to solve basic mathematical problems.

Resources to Support Local Curriculum

- A list of approved textbooks and instructional materials is posted on the VDOE [website](#).
- [Middle School Mathematics Formula Sheet](#) (PDF)
- So Many Ways to Order! Exemplar Mathematics Instructional Plan ([Word](#) | [PDF](#))

8.NS.2

The student will investigate and describe the relationship between the subsets of the real number system.

Students will demonstrate the following Knowledge and Skills:

- a) Describe and illustrate the relationships among the subsets of the real number system by using representations (e.g., graphic organizers, number lines). Subsets include rational numbers, irrational numbers, integers, whole numbers, and natural numbers.
- b) Classify and explain why a given number is a member of a particular subset or subsets of the real number system.
- c) Describe each subset of the set of real numbers and include examples and non-examples.

Understanding the Standard

- The subsets of real numbers include natural numbers (counting numbers), whole numbers, integers, rational and irrational numbers.
- Some numbers can belong to more than one subset of the real numbers (e.g., 4 is a natural number, a whole number, an integer, and a rational number). The attributes of one subset can be contained in whole or in part in another subset. The relationships between the subsets of the real number system can be illustrated using graphic organizers (e.g., Venn diagrams) and number lines.
- The set of natural numbers is the set of counting numbers {1, 2, 3, 4...}.
- The set of whole numbers includes the set of all the natural numbers and zero {0, 1, 2, 3...}.
- The set of integers includes the set of whole numbers and their opposites {...-2, -1, 0, 1, 2...}. Zero has no opposite and is neither positive nor negative.
- The set of rational numbers includes the set of all numbers that can be expressed as fractions in the form $\frac{a}{b}$ where a and b are integers and b does not equal zero. The decimal form of a rational number can be expressed as a terminating or repeating decimal. A few examples of rational numbers are 25, -2.3, 75%, 4.59, and $0.\overline{3}$.
- The set of irrational numbers is the set of all nonrepeating, nonterminating decimals. An irrational number cannot be written in fraction form (e.g., π , 1.232332333...).
- The real number system is comprised of all rational and irrational numbers. The subsets of the real number system can be seen in the image below.

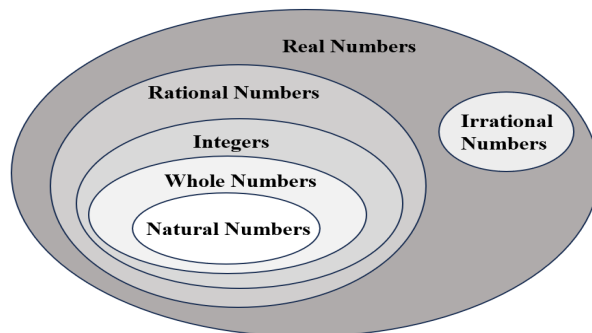

Skills in Practice

While the five process goals are expected to be embedded in each standard, the Skills in Practice highlight the most prevalent process goals in relation to the content presented.

Mathematical Communication: Real numbers can be defined as the collection of all rational numbers and irrational numbers, denoted by R . Therefore, a real number is either rational or irrational. The set of real numbers is $R = \{\dots -3, -\sqrt{2}, -\frac{1}{2}, 0, 1, \frac{4}{5}, 16\dots\}$. Number lines and/or graphic organizers are helpful when representing real numbers. Teach clear and concise mathematical language and support students' use of the language to help students effectively communicate their understanding of mathematical concepts.

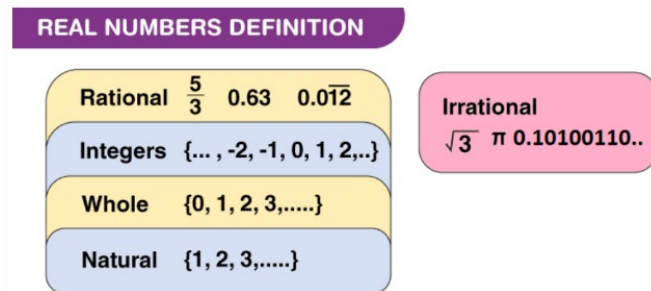

Mathematical Representations: As real numbers consist of rational numbers and irrational numbers, it can be said that integers, whole numbers, and natural numbers are also subsets of real numbers. This relation can also be understood from the figure below. Simply providing a definition of a term is not sufficient for developing students' understanding of mathematical vocabulary and concepts. Link new vocabulary to a variety of examples. A graphic organizer, such the one below, is student-friendly and combines definitions with both

visual and symbolic depictions of a word’s meaning. Extend students’ understanding by having them justify the subsets characteristics and provide examples and non-examples.

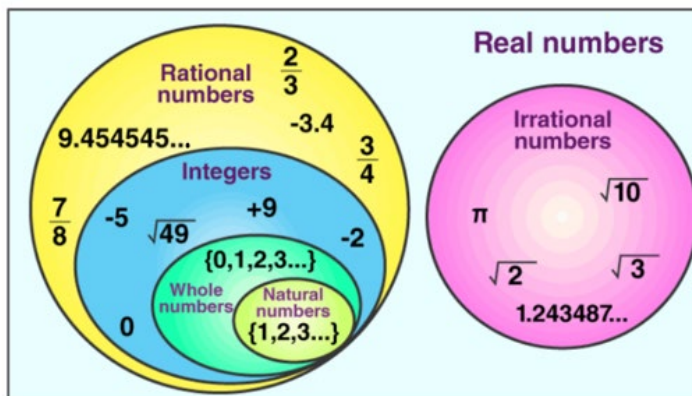

Students can draw the following conclusions using the given representation –

- The set of natural numbers is the set of counting numbers $\{1, 2, 3, 4, \dots\}$.
- The set of whole numbers includes the set of all the natural numbers and zero $\{0, 1, 2, 3, \dots\}$.
- The set of integers includes the set of whole numbers and their opposites $\{\dots -2, -1, 0, 1, 2, \dots\}$. Zero has no opposite and is neither positive nor negative.
- Integers, whole numbers, natural numbers are subsets of rational numbers.
- Rational numbers (including integers, whole numbers, natural numbers) and irrational numbers are the subsets of real numbers.

Concepts and Connections

CONCEPTS

There are multiple representations of numbers and relationships among numbers that provide meaning and structure and allow for sense-making.

CONNECTIONS

- *Within the grade level/course:*
 - 8.NS.1 – The student will compare and order real numbers and determine the relationships between real numbers.
- *Vertical Progression:*
 - 5.NS.2b – The student will classify, compare, and contrast whole numbers up to 100 using the characteristics prime and composite.

- 7.NS.1 – The student will investigate and describe the concept of exponents for powers of ten and compare and order numbers greater than zero written in scientific notation.
- 7.NS.2 – The student will reason and use multiple strategies to compare and order rational numbers.

Resources to Support Local Curriculum

- A list of approved textbooks and instructional materials is posted on the VDOE [website](#).
- [Middle School Mathematics Formula Sheet](#) (PDF)

Computation and Estimation

In K-12 mathematics, computation and estimation are integral to developing mathematical proficiency. Computation refers to the process of performing numerical operations, such as addition, subtraction, multiplication, and division. It involves applying strategies and algorithms to solve arithmetic problems accurately and efficiently. Estimation is the process of obtaining a reasonable or close approximation of a result without performing an exact calculation. Estimation is particularly useful when an exact answer is not required, especially in real-world situations, and when assessing the reasonableness of an answer. Computation and estimation are used to support problem solving, critical thinking, and mathematical reasoning by providing students with a range of approaches to solve mathematics problems quickly and accurately.

In Grade 8, students use estimation and the operations of addition, subtraction, multiplication, and division to model, represent, and solve different types of problems with rational numbers. At this grade level, students estimate and apply proportional reasoning and computational procedures to solve contextual problems.

It is critical at this grade level that while students build their conceptual understanding through concrete and pictorial representations, that students also apply standard algorithms when performing operations as specified within the parameters of each standard of this strand. At this grade level, students become more efficient with problem solving strategies. Fluent use of standard algorithms not only depends on automatic retrieval (automaticity learned during the elementary grades), but also reinforces them. Automaticity further grounds students' entry points and the structures needed to solve contextual problems and execute mathematical procedures with real numbers.

8.CE.1

The student will estimate and apply proportional reasoning and computational procedures to solve contextual problems.

Students will demonstrate the following Knowledge and Skills:

- a) Estimate and solve contextual problems that require the computation of one discount or markup and the resulting sale price.
- b) Estimate and solve contextual problems that require the computation of the sales tax, tip and resulting total.
- c) Estimate and solve contextual problems that require the computation of the percent increase or decrease.

Understanding the Standard

- Proportional reasoning can be used to solve contextual problems that include percents where scaling up and down is efficient.
- A percent is a ratio with a denominator of 100.

- Contextual problems may include, but are not limited to, those related to economics, sports, science, social science, transportation, and health. Some examples include problems involving fees, the discount or markup price on a product, temperature, sales tax, tip, and installment buying.
- Percent increase and percent decrease are both percents of change measuring the percent a quantity increases or decreases.

$$\text{Percent of change} = \frac{\text{new} - \text{original}}{\text{original}} \cdot 100$$

For example –

- Gasoline was originally \$2.25 per gallon. It is now \$2.55 per gallon. What is the percent of increase?

$$\frac{2.55 - 2.25}{2.25} \cdot 100$$

$$\frac{0.30}{2.25} \cdot 100 = 0.13 \cdot 100 = 13$$

increase of 13%

- A computer was originally \$1200. It is now only \$900. What is the percent of decrease?

$$\frac{900 - 1200}{1200} \cdot 100$$

$$\frac{-300}{1200} \cdot 100 = -0.25 \cdot 100 = -25$$

decrease of 25%

Skills in Practice

While the five process goals are expected to be embedded in each standard, the Skills in Practice highlight the most prevalent process goals in relation to the content presented.

Mathematical Problem Solving: Problem solving requires both an ability to correctly define a problem and find a solution for it. Model effective practices that demonstrate for students how to arrive at their solutions through estimation, exactness, and justification. To unpack contextual problems, guide students through the problem-solving process by taking care to annotate essential vocabulary (not “key words”) related to applied operations.

For example –

- Understand the problem by reading and then re-reading the problem; visualize the problem or draw a picture; underline or highlight the important information and essential vocabulary within the problem.
- Create a plan by deciding what to do and how to solve the problem using the applicable operation(s).

- Carry out the plan by showing all work to represent thinking (e.g., using symbols, words, concrete manipulatives, pictorial representations).
- Check the solution by determining if the solution answers the question asked in the contextual problem. During this phase of problem solving, it is essential that students are exposed to strategies that allow them to determine the reasonableness of their responses and solutions; and to support multiple mathematically sound and accurate ways of arriving at a solution.
- Graphic organizers such as the four-square model (Polya method) can help students to organize their thinking as they solve contextual problems –

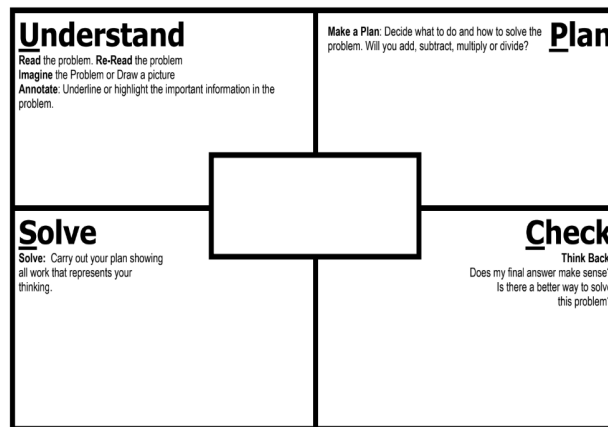

- Prior to solving problems, students should be encouraged to estimate the solution. When estimating discount, markup, tax, tip, and total students may use a variety of strategies including rounding and compatible numbers where percentage or dollar amounts could be adjusted.
- As students solve contextual problems, ask questions such as –
 - Are there multiple ways to solve a single problem?
 - How do you know that you have provided a reasonable answer?
 - What role does estimation play in solving contextual problems?
- Once students have had an opportunity to solve a contextual problem, discuss the multiple strategies being used and how to represent them mathematically. Help students see the connections between different strategies. Discussing connections between multiple strategies encourages students to become flexible problem-solvers, so they can ultimately determine which strategies are more efficient and why. For example, students may use the following strategies to solve the problem below –

A pair of shoes cost \$109 at Sneaker City. At the Labor Day sale, they are 20% off. What is the sale price of the shoes?

$$\begin{aligned} \text{Strategy 1: } & \$109 \cdot 0.2 = \$21.80 \\ & \$109 - \$21.80 = \$87.20 \end{aligned}$$

$$\text{Strategy 2: } \$109 \cdot 0.8 = \$87.20$$

$$\begin{aligned} \text{Strategy 3: } & \frac{x}{109} = \frac{20}{100} \\ & 100x = 2,180 \\ & x = 21.80 \\ & 109 - 21.80 = 87.20 \end{aligned}$$

Ask questions such as –

- How are these strategies alike? How are they different from each other?
 - What connections can be made between these strategies?
 - How do these different strategies arrive at the same solution?
 - Which strategy do you think is the most efficient? Why?
- Several contextual problems have been provided below to serve as examples with common misconceptions –
 - Example (Sales Tax): Trey buys one bag of chips for \$2.75, three sticky buns for \$1.35 each, and two sodas for \$3.60 each. Sales tax rate for items purchased is 5.5%. How much does Trey pay for all of the items he purchased, including tax?

A common error a student may make is finding and including the sales tax for purchasing one bag of chips, one sticky bun, and one soda. This indicates that the student focused on the price of each item rather than the quantity of each item purchased. Students may benefit from additional practice with multistep contextual problems. A student may also benefit from highlighting the essential vocabulary in the question to identify the quantity and price of items purchased. Other potential errors a student may make are only finding the sales tax amount or subtracting the amount of tax from the cost of the items.

- Example (Discount): During a sale, a skateboard is reduced by 50%. If the original price was \$70, what is the discounted price?

A common error a student may make is writing the discount amount as the sale price instead of subtracting it from the original amount. Students will benefit from additional practice with multistep contextual problems, highlighting essential vocabulary to determine whether only the discount is to be determined or the full sales price.

- Example (Percent Increase/Decrease): In the month of May 2019, Norfolk International Airport had approximately 360,000 passengers. In the month of May 2020, they had approximately 46,000 passengers. What is the percent decrease in the number of passengers from May 2019 to May 2020?

A student may state the percent change is 682% by incorrectly computing the percent of change, $\left(\frac{360000-46000}{46000}\right)$. Another common misconception a student may make when finding percent of decrease is to subtract the two values and attach a

percent to that difference, resulting in a 314,000% decrease. Both errors indicate the student may not understand the concept of a decrease in percentages. Another error a student may make is incorrectly calculating the initial percent of decrease $\left(\frac{360000-46000}{360000}\right)$ but state the percentage of change as 8.72% or 8%. This error indicates the student may not understand that the amount computed from this calculation must be converted to a percent. The student may benefit from additional practice with percent change problems that result in an answer of *over 100%*.

- Example (Markup): A shoe distributor sells a particular pair of shoes to stores for \$42.80. The store sells these pairs of shoes to customers at a 35% markup. How much money does the store make from selling one pair of shoes to a customer?

A common error a student may make is providing an answer that represents the markup price a customer pays for one pair of shoes. This may indicate that the student does not understand the relationship between part (amount of markup) and whole (price a customer pays). A student making this error may benefit from additional practice with contextual problems and drawing a picture to represent the problem.

Markup may pose a challenge to students. Markup can be described as the amount the price increased expressed as a percentage of the purchase price. For example, increasing an item by 25% is the same as selling it at $100\% + 25\% = 125\%$, the price at which it was purchased. This can be written using decimals by saying that a markup of 25% is the same as $0.25 + 1$, where 1 represents 100% of the purchase price and 0.25 is the 25% markup. In this example, the 25% which the price was increased is known as the markup rate. The selling price would be determined using the standard algorithm using the equation $\text{part} = \text{percent} \cdot \text{whole}$.

Mathematical Communication: Recall multiple problem types learned at the elementary grades and apply them to contextual problems as students advance in their understanding of more complex contextual problems and structures. Teach students a solution method for solving each problem type. Introduce a solution method using a worked-out example. Talk through the problem-solving process and connect the relevant problem information to the worked-out example. Say out loud the decisions that were made to solve the problem at each step. Then demonstrate how to apply the solution method by solving a similar problem with students using that method. Discuss each decision made and ask students guiding questions to engage them as problems are solved.

Mathematical Reasoning: Solving problems in contextual situations enhances proficiency with estimation strategies. Reasoning skills are essential for solving problems effectively and strategically. Reasoning involves analyzing information, identifying assumptions, evaluating evidence, and drawing logical conclusions. When solving problems in context, students may have difficulty understanding which operation(s) to use and may use the wrong operation(s) when solving. To help students derive the meaning of which operation to apply, ask students how thinking about the meaning of addition can help when solving word problems. Give students a chance to explain

individually and share their thoughts with each other. Repeat this process for subtraction, multiplication, and division. Have students explain the action of the word to move away from a reliance on “key words.” For example –

- Addition:
 - Finding the total quantity of separate quantities
 - Combining two or more quantities
- Subtraction:
 - Finding how much more or how much less
 - Finding how much further
 - Finding the difference between two quantities
 - Determining a quantity when taking one amount from another
- Multiplication:
 - Finding the quantity needed for x number of people or x number of something
 - Having equal groups and finding the total of all groups
 - Finding a part (fraction) of a whole number
 - Taking a part of a part (fraction of a fraction)
- Division:
 - Dividing an item (or quantity) into equal sized pieces
 - Dividing a quantity into equal groups
 - Using an equal amount of something over time
 - Determining how many fractional groups can be made from a quantity

Mathematical Connections: Students must connect fluency of facts, concepts, procedures, and mathematical language through mathematical reasoning to effectively solve contextual problems. Fluency with rational numbers at this grade level will help with improving logical reasoning skills, which will then lend themselves to solving contextual problems. In the following examples students must use their previous understanding of computations with real numbers (e.g., decimals, percents, and fractions) to arrive at an exact solution. Next, students must apply their understanding of mathematical language to determine which operation(s) to use, and with this information, design a plan to solve the solution. Lastly, students must determine the reasonableness of their solution by providing their reasoning. Common misconceptions are given below when either fluency of facts, concepts, procedures, or misinterpretation of mathematical language can derail students’ provision of a correct response –

- Micheal has \$425.50 before he goes shopping. He spends 20% of it on groceries and then $\frac{2}{5}$ of the remaining amount on supplies for an art project. How much money does Michael have left over?

A common error students may make is determining how much money Michael has spent instead of how much he has left over. This may indicate students could benefit from more practice in determining what the question is asking and developing the steps needed to answer that question. Another common mistake students may make is to add 20% and $\frac{2}{5}$ or 40%, then multiply the amount of money by 60% to determine what was spent. This demonstrates that students may not understand the correct sequence of calculations necessary to solve the problem. Creating a visual model will help students see the sequence of events and to justify the reasonableness of their solutions.

- Two friends went out to dinner. The total bill was \$40.00 before tax and tip. The tax rate was 6%. They wanted to tip 20% on the total before tax. Which expressions could be used to determine the total cost including tax and tip?

$$40(1.26) \quad 40(0.06) + 40(0.2) \quad 40 + 40(0.2 + 0.06) \quad 40 + 40(0.06) + 40(0.2)$$

It may be a struggle for some students to understand that there are multiple ways to solve and represent the same problem – $40(1.26)$, $40 + 40(0.2 + 0.06)$, and $40 + 40(0.06) + 40(0.2)$ are all expressions that can be used to determine the total cost of the dinner, including tax and tip.

Lead a discussion with students about what they notice and wonder about each expression, sharing what is alike and different. Students may have difficulty making connections to generating equivalent algebraic expressions and the use of the distributive property when solving this type of problem. Model how to think through what the numbers in each expression represent and help students see the similarities/differences between each approach.

Help students understand that the amount of the total bill is missing from the expression $40(0.06) + 40(0.2)$, and that this method will only provide the tax and tip. Students may have trouble understanding how $40(1.26)$ could be used to determine the total. It may be helpful to break down the amount 1.26 into expanded form ($1.00 + 0.20 + 0.06$) so students can visualize what each part of the number represents.

Concepts and Connections

CONCEPTS

Estimation and the operations of addition, subtraction, multiplication, and division, allow us to model, represent, and solve different types of problems with rational numbers.

CONNECTIONS

- Within the grade level/course:*
 - 8.PFA.1 – The student will represent, simplify, and generate equivalent algebraic expressions in one variable.

- 8.PFA.4 – The student will write and solve multistep linear equations in one variable, including problems in context that require the solution of a multistep linear equation in one variable.
- *Vertical Progression:*
 - 7.CE.2 – The student will solve problems, including those in context, including proportional relationships.
 - A.EI.1f – Verify possible solution(s) to multistep linear equations and inequalities in one variable algebraically, graphically, and with technology to justify the reasonableness of the answer(s). Explain the solution method and interpret solutions for problems given in context.
 - A.EI.2h – Verify possible solution(s) to a system of two linear equations, a linear inequality in two variables, or a system of two linear inequalities algebraically, graphically, and with technology to justify the reasonableness of the answer(s). Explain the solution method and interpret solutions for problems given in context.
 - A.EI.3c – Verify possible solution(s) to a quadratic equation in one variable algebraically, graphically, and with technology to justify the reasonableness of answer(s). Explain the solution method and interpret solutions for problems given in context.

Resources to Support Local Curriculum

- A list of approved textbooks and instructional materials is posted on the VDOE [website](#).
- [Middle School Mathematics Formula Sheet](#) (PDF)

Measurement and Geometry

In K-12 mathematics, measurement and geometry allow students to gain understanding of the attributes of shapes as well as develop an understanding of standard units of measurement. Measurement and geometry are imperative as students develop a spatial understanding of the world around them. The standards in the measurement and geometry strand aim to develop students' special reasoning, visualization, and ability to apply geometric and measurement concepts in real-world situations.

In Grade 8, students analyze and describe geometric objects, the relationships and structures among them, or the space that they occupy. These relationships can be used to classify, quantify, measure, or count one or more attributes. At this grade level, students use the relationships among pairs of angles that are vertical, adjacent, supplementary, and complementary to determine the measure of unknown angles. Students will investigate and determine the surface area of square-based pyramids and the volume of cones and square-based pyramids. Students will apply translations and reflections of polygons in the coordinate plane and apply the Pythagorean Theorem to solve problems involving right triangles. Additionally, students will solve area and perimeter problems involving composite plane figures.

8.MG.1

The student will use the relationships among pairs of angles that are vertical angles, adjacent angles, supplementary angles, and complementary angles to determine the measure of unknown angles.

Students will demonstrate the following Knowledge and Skills:

- Identify and describe the relationship between pairs of angles that are vertical, adjacent, supplementary, and complementary.
- Use the relationships among supplementary, complementary, vertical, and adjacent angles to solve problems, including those in context, involving the measure of unknown angles.

Understanding the Standard

- Vertical angles are a pair of nonadjacent angles formed by two intersecting lines. Vertical angles are congruent and share a common vertex. In the image below, Angles 1 and 3 are vertical angles. Angles 2 and 4 are also vertical angles.

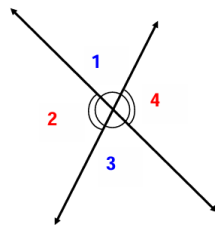

$\angle 1$ and $\angle 3$ are vertical angles.

$\angle 2$ and $\angle 4$ are vertical angles.

$$\angle 1 \cong \angle 3 \text{ and } \angle 2 \cong \angle 4$$

- Complementary angles are any two angles such that the sum of their measures is 90° . In the image below, Angles 1 and 2 are complementary angles.

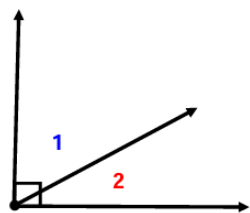

Fig 1

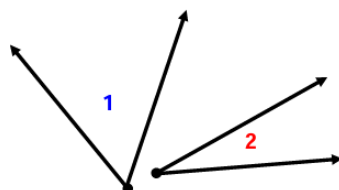

Fig 2

$$m\angle 1 + m\angle 2 = 90^\circ$$

in each figure

- Supplementary angles are any two angles such that the sum of their measures is 180° . In the image below, Angles 1 and 2 are supplementary angles.

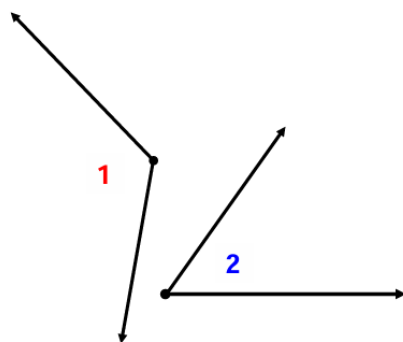

Fig 1

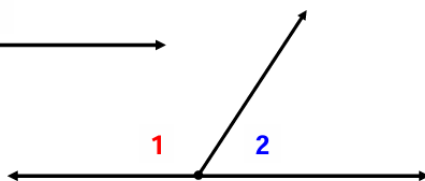

Fig 2

$$m\angle 1 + m\angle 2 = 180^\circ$$

in each figure

- Complementary and supplementary angles may or may not be adjacent.

- Adjacent angles are any two non-overlapping angles that share a common ray and a common vertex.

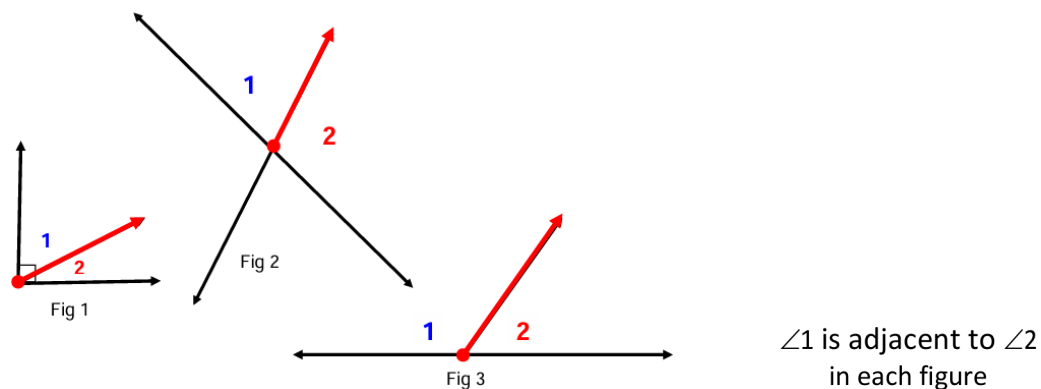

- The content in this standard provides a natural connection to 8.PFA.4. During instruction, students would benefit from opportunities to solve problems about the relationships of angles where unknown angles measures are given as expressions (e.g., a pair of vertical angles whose measures are $(6x + 38^\circ)$ and $(7x + 26^\circ)$).

Skills in Practice

While the five process goals are expected to be embedded in each standard, the Skills in Practice highlight the most prevalent process goals in relation to the content presented.

Mathematical Problem Solving: A major task for any student engaged in problem solving is to translate the quantitative information in a problem into a symbolic equation – an arithmetic/algebraic statement – necessary for solving the problem. Visual representations help students solve problems by linking the relationships between quantities in the problem with the mathematical operations needed to solve the problem. Examples with common misconceptions follow –

- Shayla wants to fix the fence pictured below but she needs to determine the measure of $\angle ABC$. She knows that $\angle DBC$ measures 108° . If $\angle ABC$ and $\angle DBC$ form a linear pair, what is the measure of $\angle ABC$?

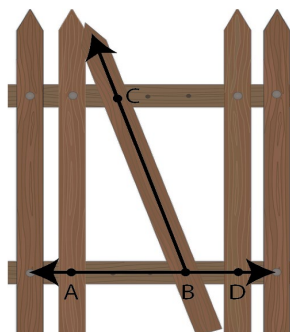

The student may have misconceptions about the relationships between the angles due to the figure being overlaid on the image of the fence. This may indicate difficulty translating a practical problem into a traditional representation of an angle pair. It might be helpful for students to re-draw the angles, separate from the fence, in order to view the referenced angle relationship more clearly.

- Use the diagram below to identify and describe the relationship between pairs of specified angles. Examples with common misconceptions follow –

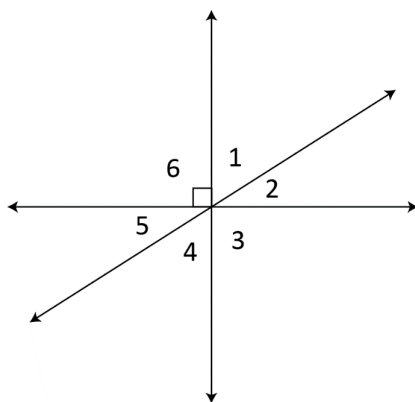

- **Identify a pair of vertical angles:** A common error a student may make is identifying angles 1 and 5 or angles 2 and 4 as vertical angles. This may indicate a need to review characteristics of vertical angles. Teachers are encouraged to provide hands-on experiences for identifying vertical angles. Items such as patty paper and angle manipulatives can be used to identify vertical angles and form conjectures about their measurements. Students may also use a protractor to verify the

angle measurements. Color-coding angle relationships may help students to differentiate between the types of angles being identified.

- **Identify a pair of complementary angles:** A common error a student may make is identifying angles 3 or 6 as complementary. Students must understand that “complementary” refers to a pair of angles measuring 90 degrees and not one right angle. This may indicate that a student has a partial understanding of the terminology but needs further reinforcement. Color-coding angle relationships may help students to differentiate between the types of angles being identified. Teachers are encouraged to provide examples of complementary angles using angle measurements and visual representations.
- **Identify an angle adjacent to $\angle 4$:** A common error a student may make is identifying angle 1 as adjacent to angle 4. This may indicate that a student is recalling the relationship between vertical angles. It might be helpful for students to highlight or outline angle 4 before identifying adjacent angles. Color-coding angle relationships may help students to differentiate between the types of angles being identified. Teachers are encouraged to explore the meaning of adjacent and relate this relationship to real-world examples, such as neighboring apartments or classrooms that share a common wall.

Mathematical Representations: Students who learn to visually represent the mathematical information in problems prior to writing an equation are more effective at problem solving. Teachers should consistently use visual representations to solve problems, including those in context, where angle relationships are formed. Building conceptual understanding could involve dynamic software or concrete manipulatives to represent various angle relationships where the value of an angle or missing value of an expression is unknown.

- Using angle relationships to determine either the value of a variable or the entire angle measure:

Use the relationships among the angles shown in the figure to solve for x .

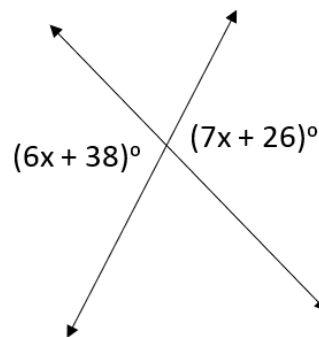

A common error a student may make is identifying the angles as supplementary and setting up the equation $(6x + 38) + (7x + 26) = 180$ to solve for the value of x . This may indicate that a student sees the lines pictured as a linear pair and therefore believes the angles have a sum of 180 degrees. It might be helpful for students to highlight or outline the angles with given information and determine their relationship before setting up an equation.

- Determining multiple missing angle measures when given one angle measure: Applying understandings of angle relationships will help students to solve complex problems using representations to determine angle measures. Consider the following problem – Determine the missing angle measures.

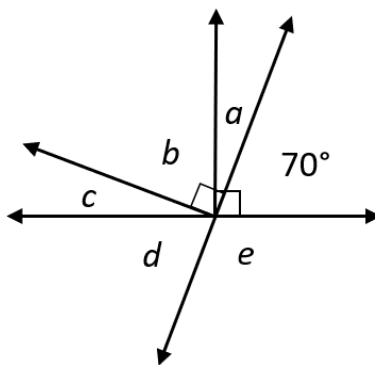

A question of this type allows students to demonstrate their understanding of the standard. Strategies of decomposition and composition to visualize complementary angles, supplementary angles, adjacent angles, vertical angles (where applicable), and linear pairs prove vital to successfully answering a problem of this nature where multiple angle relationships are pictured, and students must translate the quantitative information in a problem into a symbolic equation (an arithmetic/algebraic statement).

Concepts and Connections

CONCEPTS

Analyzing and describing geometric objects, the relationships and structures among them, or the space that they occupy can be used to classify, quantify, measure, or count one or more attributes.

CONNECTIONS

- *Within the grade level/course:*
 - There are no horizontal connections.
- *Vertical Progression:*
 - 5.MG.3 – The student will classify and measure angles and triangles, and solve problems, including those in context.

- G.TR.1 – The student will determine the relationships between the measures of angles and lengths of sides in triangles, including problems in context.
- G.RLT.2 – The student will analyze the relationships of parallel lines cut by a transversal.

ACROSS CONTENT AREAS [THEME – MODELING]

- *Computer Science:*
 - Logic and Conditional Statements concepts include conditional statements and Boolean logic.
 - Geometry and Transformations concepts include manipulating objects in computer graphics; applying geometric calculations in game development and simulations; and developing user interfaces with symmetrical and proportional layouts.
 - Ratios, Proportions, and Scaling concepts include image and game object scaling and normalizing data for machine learning models.
 - Ratios and Proportional Reasoning highlights include scaling in graphics and simulations – scale images in graphic design, adjusting resolution in digital media, and resizing elements for UX design; algorithm efficiency and performance analysis – utilized in application to define of runtime or memory usage changes as input size grows; data encoding and compression – proportional reasoning helps in lossy compression techniques.
 - Geometry highlights include game development and graphics programming – 2D and 3D coordinate systems used in positioning objects, animations, and rendering; computer vision and image processing – shape detection, edge recognition, and transformations (rotation, scaling, and translation); and geographic information systems (GIS) – coordinate systems are used to map and analyze real-world data.
- *Physical Science:*
 - PS.2 The student will investigate and understand that matter is composed of atoms. To meet this standard, students are expected to use models to describe atomic structure and relate kinetic molecular theory to particle motion.
 - PS.3 The student will investigate and understand that matter has properties and is conserved in chemical and physical processes. To meet this standard, students are expected to use models to explain densities.
 - PS.5 The student will investigate and understand that energy is conserved. To meet this standard, students are expected to use models to explain energy transfer.
 - PS.6 The student will investigate and understand that waves are important in the movement of energy. To meet this standard, students are expected to use models to describe wave characteristics and to explain energy transfer and wave interactions.

- PS.7 The student will investigate and understand that electromagnetic radiation has characteristics. To meet this standard, students are expected use models to explain interrelationships in electromagnetic waves and explain how electromagnetic radiation interacts with materials.
- PS.8 The student will investigate and understand that work, force, and motion are related. To meet this standard, students are expected to use models to represent and explain Newton’s laws.
- PS.9 The student will investigate and understand that there are basic principles of electricity and magnetism. To meet this standard, students are expected to use models to explain imbalance of charges, illustrate energy transfer in elective circuits, and explain function of semiconductors.

Resources to Support Local Curriculum

- A list of approved textbooks and instructional materials is posted on the VDOE [website](#).
- [Middle School Mathematics Formula Sheet](#) (PDF)

8.MG.2

The student will investigate and determine the surface area of square-based pyramids and the volume of cones and square-based pyramids.

Students will demonstrate the following Knowledge and Skills:

- Determine the surface area of square-based pyramids by using concrete objects, nets, diagrams, and formulas.
- Determine the volume of cones and square-based pyramids, using concrete objects, diagrams, and formulas.
- Examine and explain the relationship between the volume of cones and cylinders, and the volume of rectangular prisms and square based pyramids.
- Solve problems in context involving volume of cones and square-based pyramids and the surface area of square-based pyramids.

Understanding the Standard

- A polyhedron is a solid figure whose faces are all polygons.
- A net is a two-dimensional representation of a three-dimensional figure that can be folded into a model of the three-dimensional figure.
- Surface area of a solid figure is the sum of the areas of the surfaces of the figure.
- Volume is the amount a container holds.
- A rectangular prism is a polyhedron that has a congruent pair of parallel rectangular bases and four faces that are rectangles. A rectangular prism has eight vertices and twelve edges. In Grade 8, prisms are limited to right prisms with bases that are rectangles.
- The volume of prisms can be found by determining the area of the base and multiplying that by the height (e.g., $V = Bh$).

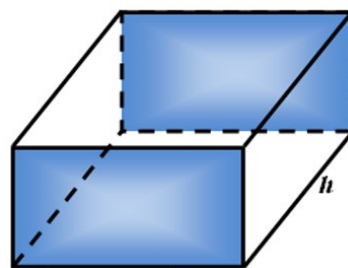

- A cone is a solid figure formed by a face called a base that is joined to a vertex (apex) by a curved surface. In Grade 8, cones are limited to right circular cones.

- The volume of a cone is found by using $V = \frac{1}{3}\pi r^2 h$ where h is the height and πr^2 is the area of the base.

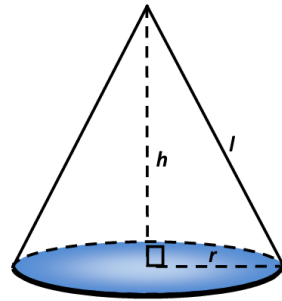

r = radius of base
 h = height
 l = slant height

- A square-based pyramid is a polyhedron with a square base and four faces that are congruent triangles with a common vertex (apex) above the base. In Grade 8, pyramids are limited to right regular pyramids with a square base.
- The volume of a pyramid is found by using the formula $V = \frac{1}{3}Bh$, where B is the area of the base and h is the height.
- The surface area of a pyramid is the sum of the areas of the triangular faces and the area of the base, found by using the formula $SA = \frac{1}{2}lp + B$, where l is the slant height, p is the perimeter of the base and B is the area of the base.

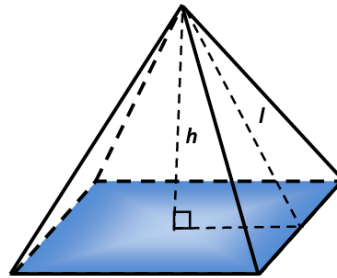

B = area of square base
 p = perimeter of base
 h = height
 l = slant height

- A cylinder is a solid figure formed by two congruent parallel faces called bases joined by a curved surface.

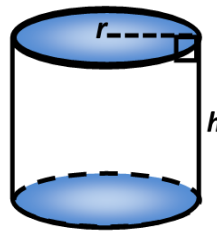

- The formulas for determining the volume of cones and cylinders are related. For cones, the volume is $\frac{1}{3}$ of the volume of the cylinder with the same size base and height. The volume of a cone is found by using $V = \frac{1}{3}\pi r^2 h$. The volume of a cylinder is the area of the base of the cylinder multiplied by the height, found by using the formula, $V = \pi r^2 h$, where h is the height and πr^2 is the area of the base.
- The formulas for determining the volume of pyramids and rectangular prisms are related. For pyramids, the volume is $\frac{1}{3}$ of the volume of the rectangular prism with the same size base and height. The volume of a square pyramid is found by using $V = \frac{1}{3}Bh$. The volume of a rectangular prism can be found using the formula, $V = Bh$, where B is the area of the base, and h is the height.
- The relationship between the volume of a cone and cylinder and the volume of a pyramid and rectangular prism with equivalent base areas and heights is a ratio of 1 to 3. This relationship can be explored with concrete materials.

Skills in Practice

While the five process goals are expected to be embedded in each standard, the Skills in Practice highlight the most prevalent process goals in relation to the content presented.

Mathematical Problem Solving:

- The volume of this cone may be expressed as 141.37cm^3 or $45\pi\text{cm}^3$.

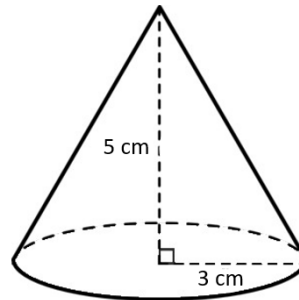

- Consider the following examples and misconceptions when working with students –
 - Find the volume of the cone:

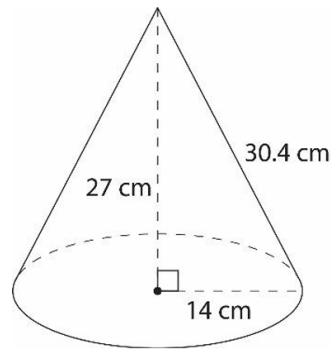

A common misconception a student may have is using the slant height of the cone instead of the height to calculate the volume – incorrectly calculating the volume as 6,239.6 cubic centimeters (cm³). This may indicate a need to emphasize vocabulary associated with cones and the formula for volume. When solving for volume of a cone, it might be helpful for the student to label which values they will use as the radius and height.

A student may also make an error when calculating the square of the radius. When substituting values into the formula $V = \frac{1}{3} \pi r^2 h$, students should carefully follow the order of operations. This error may indicate a need to revisit evaluating an algebraic expression for given replacement values of the variables. Teachers may consider reviewing the meaning of an exponent (power) by having the student write the expression in expanded form. Students should be encouraged to use reasoning and problem solving to justify the formula by using relational solids.

- Find the surface area of the square-based pyramid.

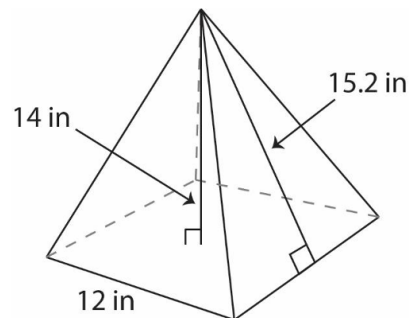

A common error a student may make is incorrectly using the height as the slant height, substituting 14 for l in the formula. Another common error a student may make is incorrectly using the side length of the base as the perimeter, substituting 12 for p in the formula. A student may also multiply the side length by itself to find the perimeter, incorrectly substituting 144 for p .

Students may make incorrectly use the side length of the base as the area of the base, substituting 12 for B in the formula. A student may also add the side lengths to find the area of the base, incorrectly substituting 48 for B . These errors may indicate a need to emphasize vocabulary associated with square-based pyramids and the formula for surface area. Teachers should consider providing students with relational solids and demonstrate how to identify the dimensions of the figure and, in this case, distinguish between the height and the slant height.

Students may provide a correct solution either without units or using cubic units. This may indicate a need to emphasize the appropriate application of units for surface area. Further, it may be helpful for teachers to emphasize a structure that will allow students to clearly organize their work. For example, when calculating the perimeter (p) and the area of the base (B), it might be helpful for the student to first separate their paper into two columns. Secondly, write the surface area formula in the first column. Then, in the second column, calculate the perimeter and area of the base.

Students should be encouraged to use reasoning and problem solving to justify the formula using nets. Teachers are encouraged to provide students with concrete nets of square-based pyramids before transitioning to the pictorial representation to support students with misconceptions and errors about the dimensions of such figures. Teachers should allow students to practice evaluating the formula by exploring the Desmos scientific calculator capabilities.

- The *Middle School Mathematics Formula Sheet* should be used in tandem with this standard to help students use the appropriate formula when solving stand-alone problems or problems in context.

Mathematical Reasoning: When solving contextual problems, students should look for essential vocabulary to determine whether the problem is requiring applications of volume or surface area. Contexts such as filling a tank (volume) or wrapping a present (surface area) are not always explicitly written in the phrasing like “find the volume or surface area of x figure.” Therefore, students should have exposure to problems that are in context as these represent real-world applications of surface area and volume.

- Students must understand the relationship between the volume of cones and cylinders, and the volume of rectangular prisms and square based pyramids. For example, the volume of a pyramid is $\frac{1}{3}$ the volume of the prism that encloses it. This is proven by approximating the volume using prisms.
 - Model a pyramid as a stack of prisms, like building a pyramid out of blocks. The model below has a volume that is greater than the pyramid's volume. The more, thinner layers, students will get closer and closer to the volume of the pyramid.

Since prism-like figures can have any closed, two-dimensional figure for the base, and since students can slide the prisms without changing the volume, the ratio holds true for all pyramid-like figures, including cones.

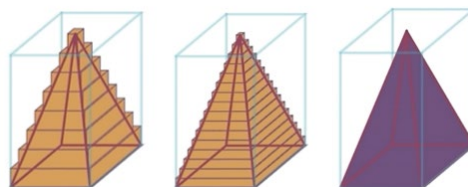

Number of layers	Volume of block pyramid approximation
	Volume of prism
4	≈ 0.469
16	≈ 0.365
64	≈ 0.341
256	≈ 0.335
1024	≈ 0.334
4096	≈ 0.333
∞	$\frac{1}{3}$

- Mathematical Connections:** Nets should be used to create connections between the two-dimensional representation of a three-dimensional figure for students to develop formulas for the surface area of square-based pyramids and volume of cones and square-based pyramids. The use of nets will allow students the opportunity to unpack problems when given in context while providing teachers with the ability to work through misconceptions that students may have with these concepts. Using the cone as an example, teachers can use nets to help students determine its parts. Discussion to help students understand these relationships may include:

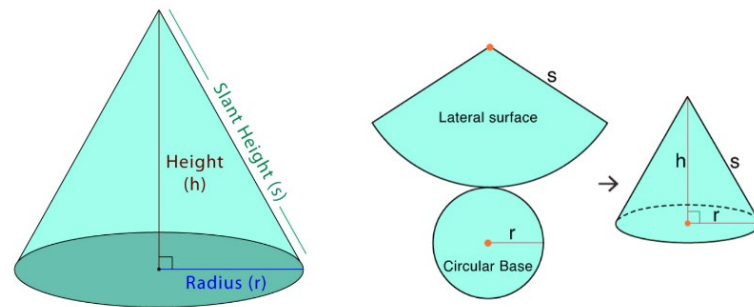

- To find the height of a cone given its net, measure the length of the triangular portion of the net. This measurement represents the height of the cone.
- To find the radius of a cone given its net, measure the radius of the circular portion of the net. This measurement represents the radius of the cone.
- What is the relationship between the net of a cone and its volume? The volume of the cone can be calculated from the height and radius of the cone.
- To visualize the net of a cone and understand its properties, use a physical model of the net. Construct the net by unfolding the lateral surface of the cone and flattening it into a two-dimensional shape.
- To construct a cone from its net, cut out the circular and triangular portions of the net and fold along the dotted lines to form a cone.
- Similar questioning can be conducted when examining nets of square-based pyramids.

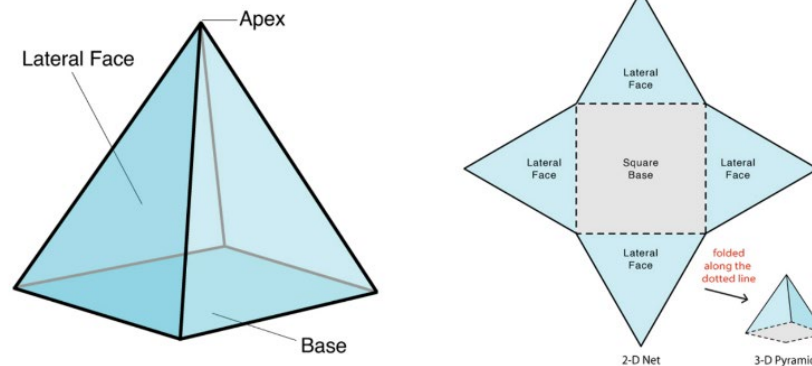

Concepts and Connections

CONCEPTS

Analyzing and describing geometric objects, the relationships and structures among them, or the space that they occupy can be used to classify, quantify, measure, or count one or more attributes.

CONNECTIONS

- *Within the grade level/course:*
 - 8.MG.5 – The student will solve area and perimeter problems involving composite plane figures, including those in context.
- *Vertical Progression:*
 - 7.MG.1 – The student will investigate and determine the volume formula for right cylinders and the surface area formulas for rectangular prisms and right cylinders and apply the formulas in context.
 - G.DF.1 – The student will create models and solve problems, including those in context, involving surface area and volume of rectangular and triangular prisms, cylinders, cones, pyramids, and spheres.

ACROSS CONTENT AREAS

Reference 8.MG.1.

Resources to Support Local Curriculum

- A list of approved textbooks and instructional materials is posted on the VDOE [website](#).
- [Middle School Mathematics Formula Sheet](#) (PDF)

8.MG.3

The student will apply translations and reflections to polygons in the coordinate plane.

Students will demonstrate the following Knowledge and Skills:

- Given a preimage in the coordinate plane, identify the coordinates of the image of a polygon that has been translated vertically, horizontally, or a combination of both.
- Given a preimage in the coordinate plane, identify the coordinates of the image of a polygon that has been reflected over the x - or y -axis.
- Given a preimage in the coordinate plane, identify the coordinates of the image of a polygon that has been translated and reflected over the x - or y -axis or reflected over the x - or y -axis and then translated.
- Sketch the image of a polygon that has been translated vertically, horizontally, or a combination of both.
- Sketch the image of a polygon that has been reflected over the x - or y -axis.
- Sketch the image of a polygon that has been translated and reflected over the x - or y -axis, or reflected over the x - or y -axis and then translated.
- Identify and describe transformations in context (e.g., tiling, fabric, wallpaper designs, art).

Understanding the Standard

- A transformation of a figure, called the preimage, changes the size, shape, and/or position of the figure to a new figure, called the image.
- A transformation of preimage point A can be denoted as the image A' (read as “A prime”).
- A reflection is a transformation in which an image is formed by reflecting the preimage over a line called the line of reflection. Each point on the image is the same distance from the line of reflection as the corresponding point in the preimage.

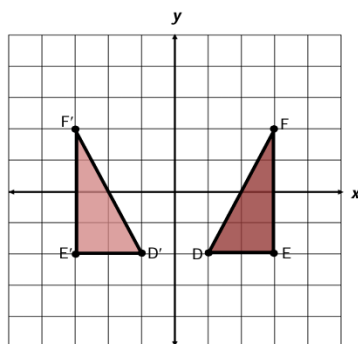

The preimage of triangle DEF is reflected across the y -axis to create the image $D'E'F'$

Preimage	Image
D(1,-2)	D'(-1,-2)
E(3,-2)	E'(-3,-2)
F(3,2)	F'(-3,2)

- Reflections change the orientation of the image.
- A translation is a transformation in which an image is formed by moving every point on the preimage the same distance in the same direction. Linear equations of the form $y = mx + 0$ will be translated to $y = mx + b$ in SOL 8.PFA.3a,b.

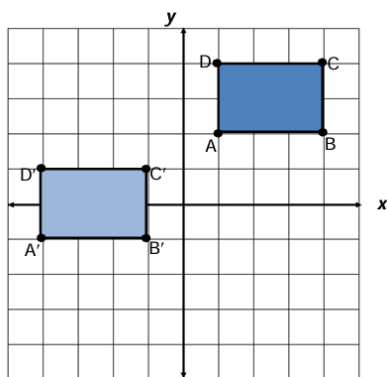

The preimage of rectangle ABCD is translated 5 units to the left and 3 units down to create the image A'B'C'D'

Preimage	Image
A(1,2)	A'(-4,-1)
B(4,2)	B'(-1,-1)
C(4,4)	C'(1,1)
D(1,4)	D'(-4,1)

- Translations and reflections maintain congruence between the preimage and image but change location on the coordinate plane.
- Students in Grade 7 had experiences with dilations. A dilation is a transformation in which an image is formed by enlarging or reducing the preimage proportionally by a scale factor from the center of dilation (limited to the origin in Grade 7). A dilation of a figure and the original figure are similar. The center of dilation may or may not be on the preimage.
- The result of first translating and then reflecting over the x - or y -axis may not result in the same transformation of reflecting over the x - or y -axis and then translating.

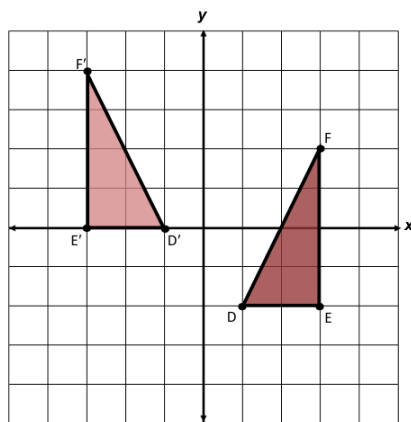

Figure DEF is reflected over the y -axis and translated up 2 units to create the image D'E'F'.

Preimage	Image
D(1,-2)	D'(-1,0)
E(3,-2)	E'(-3,0)
F(3,2)	F'(-3,4)

- Contextual applications of transformations may include, but are not limited to, the following:

- A reflection of a boat in water shows an image of the boat flipped upside down with the water line being the line of reflection.
- A translation of a figure on a wallpaper pattern shows the same figure slid the same distance in the same direction.
- A dilation of a model airplane is the production model of the airplane.

Skills in Practice

While the five process goals are expected to be embedded in each standard, the Skills in Practice highlight the most prevalent process goals in relation to the content presented.

Mathematical Communication:

- Have each student draw a figure on graph paper and complete five different transformations of a figure. When completing the transformations, students should work within the parameters of this standard (e.g., sketch the image of a polygon that has been reflected over the x - or y -axis). Have students write out the directions for these five transformations and exchange them with other students, who will then follow the directions to create the same transformations.
- Engage students in discourse that will elicit their understanding of this standard. For example –
 - What is different about describing locations and transformations on a two-dimensional surface and in space?
 - What does it mean to transform a polygon?
 - What are ways that performing a transformation could change a polygon?
 - How do you determine the coordinates of an image after a transformation?
 - What stayed the same and what changed from your preimage to your image?
 - Was the order in which the transformations were applied important? Why?

Mathematical Connections: There are four common types of transformations - translation, reflection, dilation, and rotation. However, for this standard, students will apply *translations* and *reflections* to polygons in the coordinate plane. Students in Grade 7 had experiences with dilations. A dilation is a transformation in which an image is formed by enlarging or reducing the preimage proportionally by a scale factor from the center of dilation (limited to the origin in Grade 7). A dilation of a figure and the original figure are similar. The center of dilation may or may not be on the preimage.

At this grade level, students will complete translations and reflections or combinations of both. As students complete these transformations, connections about the function and the result should be made. For example –

- Reflection:
 - Function: Flips the preimage and produces the mirror image.

- Result: There is no change in size, shape, or orientation.
- Translation:
 - Function: Slides or moves the preimage.
 - Result: There is no change in size or shape; only the location of the shape.

Below is an example problem type designed to guide students in establishing connections between the preimage to the image after a transformation (or combination of transformations) has occurred. As students are conducting transformations, have students summarize their observations and ask questions such as, “How does the reflection then translation of this preimage affect the coordinates of the resulting image and why? Can you justify your solutions algebraically?”

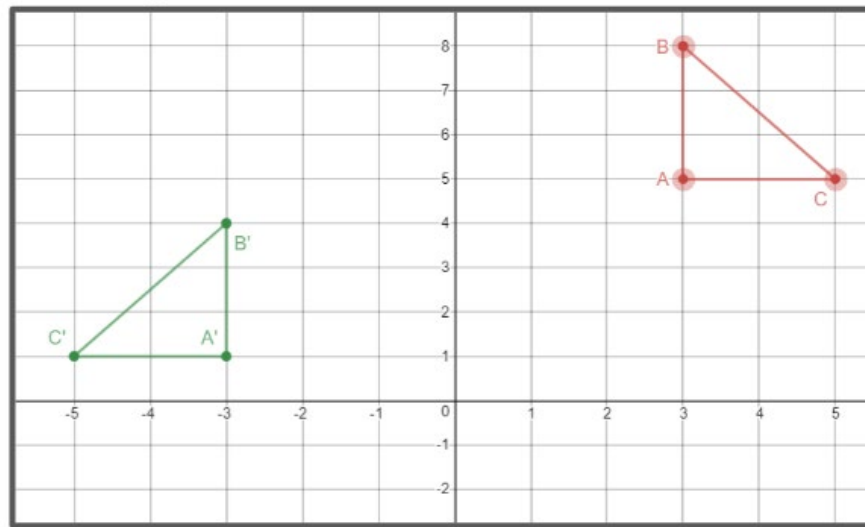

Preimage Coordinates		How would you describe what is happening from the preimage to the image? What happened to the x-coordinates? What happened to the y-coordinates?	Image Coordinates	
A			A'	
B			B'	
C			C'	

Mathematical Representations: Transformations can be represented algebraically and graphically. Students can use the formula of transformations in graphical functions to obtain the graph just by transforming the basic or the parent function, and thereby move the graph around, rather than tabulating the coordinate values.

- For example, to describe the position of the blue figure relative to the green figure, observe the relative positions of their vertices. Find the positions of A', B', and C' comparing its position with respect to the points A, B, and C. A', B', and C' are:
 - 8 units to the left of A, B, and C respectively.
 - 3 units below A, B, and C respectively.

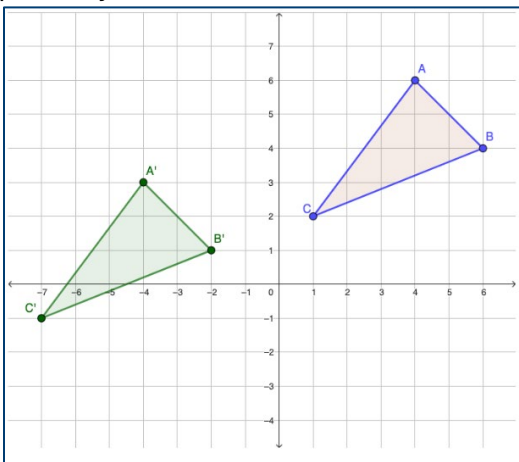

This translation can be algebraically translated as 8 units left and 3 units down as: $(x, y) \rightarrow (x - 8, y - 3)$.

- Reflections, translations, and combinations of these are rigid transformations. Students manipulate the transformations and observe that the lengths of line segments and the measurements of angles do not change. Terminology for transformations (for example, image and preimage) may be introduced in response to the need to describe the effects of rigid motions and other transformations. Initially, students view rigid motions as operations on figures. Later, students come to understand that it is not the figure that is translated or reflected, it is the plane that is moved, carrying the figure along with it. Students start thinking, not of moving one figure onto another, but of moving the plane so that the figure lands on the second. The point of this change is that it becomes possible to describe the effect of these motions in terms of coordinates.
 - Students should get a sense that rigid motions are special transformations. They should encounter and experience transformations which do not preserve lengths, do not preserve angles, or do not preserve either lengths or angles.

- Students must understand that a two-dimensional figure is congruent to another if the second can be obtained from the first by a sequence of reflections and translations.

Concepts and Connections

CONCEPTS

Analyzing and describing geometric objects, the relationships and structures among them, or the space that they occupy can be used to classify, quantify, measure, or count one or more attributes.

CONNECTIONS

- *Within the grade level/course:*
 - 8.PFA.3a,b – The student will represent and solve problems, including those in context, by using linear functions and analyzing their key characteristics (the value of the y-intercept (b) and the coordinates of the ordered pairs in graphs will be limited to integers):
 - a) Determine how adding a constant (b) to the equation of a proportional relationship $y = mx$ will translate the line on a graph.
 - b) Describe key characteristics of linear functions including slope (m), y-intercept (b), and independent and dependent variables.
- *Vertical Progression:*
 - 7.MG.4 – The student will apply dilations of polygons in the coordinate plane.
 - A.F.1b – The student will investigate, analyze, and compare linear functions algebraically and graphically, and model linear relationships. Investigate and explain how transformations to the parent function $y = x$ affect the rate of change (slope) and the y-intercept of a linear function.
- *Digital Learning Integration:*
 - 6-8 CT.B. Students find or organize data and use appropriate technologies to interpret, analyze, and represent data to construct models, predict outcomes, solve problems, and make evidence-based decisions.

ACROSS CONTENT AREAS

Reference 8.MG.1.

Resources to Support Local Curriculum

- A list of approved textbooks and instructional materials is posted on the VDOE [website](#).
- [Middle School Mathematics Formula Sheet](#) (PDF)
- Transformations Exemplar Mathematics Instructional Plan ([Word](#) | [PDF](#))

8.MG.4

The student will apply the Pythagorean Theorem to solve problems involving right triangles, including those in context.

Students will demonstrate the following Knowledge and Skills:

- Verify the Pythagorean Theorem using diagrams, concrete materials, and measurement.
- Determine whether a triangle is a right triangle given the measures of its three sides.
- Identify the parts of a right triangle (the hypotenuse and the legs) given figures in various orientations.
- Determine the measure of a side of a right triangle, given the measures of the other two sides.
- Apply the Pythagorean Theorem, and its converse, to solve problems involving right triangles in context.

Understanding the Standard

- The Pythagorean Theorem is essential for solving problems involving right triangles.
- The hypotenuse of a right triangle is the side opposite the right angle.
- The hypotenuse of a right triangle is always the longest side of the right triangle.
- The legs of a right triangle form the right angle.

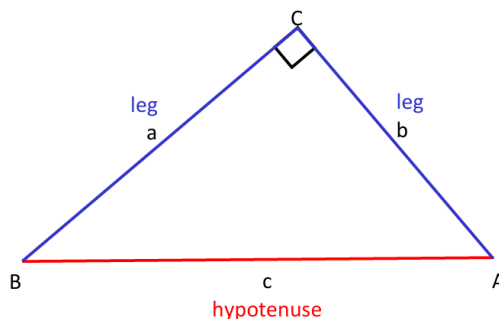

- In a right triangle, the square of the length of the hypotenuse equals the sum of the squares of the legs. This relationship is known as the Pythagorean Theorem:

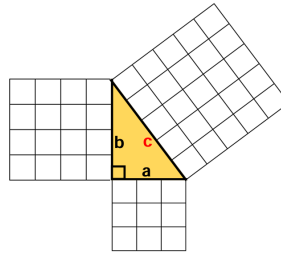

$$a^2 + b^2 = c^2$$

- The Pythagorean Theorem is used to determine the measure of any one of the three sides of a right triangle when the measures of the other two sides are known.
- The converse of the Pythagorean Theorem states that if the square of the length of the hypotenuse equals the sum of the squares of the legs in a triangle, then the triangle is a right triangle. This can be used to determine whether a triangle is a right triangle given the measures of its three sides.
- Whole number triples that are the measures of the sides of right triangles, such as (3, 4, 5) and (5, 12, 13), are commonly known as Pythagorean triples. Additional sets of Pythagorean triples can be found by applying properties for similar triangles and proportional sides. For example, doubling the sides of a triangle with sides of (3, 4, 5) creates a Pythagorean triple of (6, 8, 10).
- The Pythagorean Theorem can be applied to many contextual situations, including but not limited to, architecture, construction, sailing, and space flight.

Skills in Practice

While the five process goals are expected to be embedded in each standard, the Skills in Practice highlight the most prevalent process goals in relation to the content presented.

Mathematical Problem Solving: When students engage in this standard, they should be exposed to problems that move them from conceptual understanding (concrete or pictorial representations) to algorithms (formulas) when verifying and applying the Pythagorean Theorem and its converse in both stand-alone and solving problems in context. Examples with common errors are included below –

- Concrete to pictorial: The diagram below shows the relationship between the sides of a right triangle. Provide examples of the relationship between the sides of the square and the Pythagorean Theorem using grid paper or tiles. Use the figure to determine the shaded area of the triangle and explain your answer.

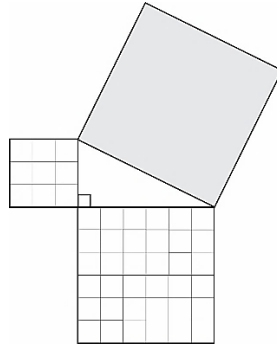

When examining each square, a common error a student may make is subtracting 9 from 36. This may indicate that a student has incorrectly identified the legs and the hypotenuse of the right triangle. It might be helpful for students to label the hypotenuse before beginning the problem. Teachers should demonstrate how to identify the hypotenuse, regardless of a right triangle's orientation. For example, students can draw an arrow through to the right angle to show that the hypotenuse is the side of a right triangle across from the right angle. This also creates the notation for a right angle:

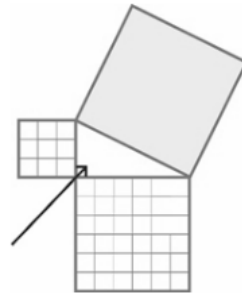

Another common error a student may make is calculating the length of the hypotenuse. This may indicate that a student can identify the process for finding a side length but does not understand the proof of the Pythagorean Theorem. Teachers are encouraged to design lessons using manipulatives, such as square tiles, to demonstrate area models and to explore the relationship between the hypotenuse and legs of a right triangle. As students explain their answers, they may determine the area of the square in a variety of ways.

Look for student answers that are mathematically correct, involve sound reasoning, and employ one or more of the following techniques: using their calculator, pencil and paper, and/or manipulatives. Students who are unable to explain their method may lack a thorough understanding of the Pythagorean Theorem. Teachers are encouraged to provide a variety of tools, such as square tiles, graph paper, or virtual manipulatives to explore the properties of right triangles.

- Contextual problem: Nikkia rode her bike two miles south. Then, she went east for three miles. How far is she from her starting point?

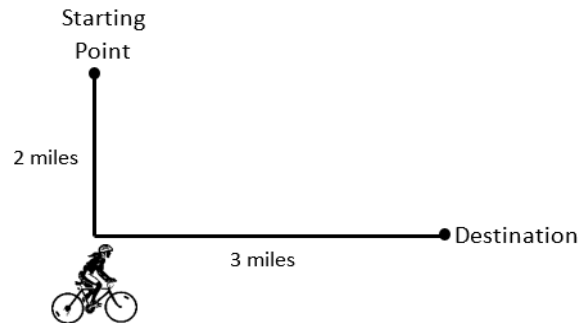

A common error a student may make is finding the sum of two and three and determining the distance to be five miles. This may indicate that a student is calculating the total distance traveled rather than the shortest distance between the starting point and destination. This may indicate that a student understands that the hypotenuse is the longest side of a right triangle, but did not consider that the leg of one right triangle might be longer than the hypotenuse of another. It might be helpful for students to square each number before attempting to identify the placement for side lengths. Teachers are encouraged to provide additional practice identifying the parts of a right triangle and Pythagorean triples.

- The *Middle School Mathematics Formula Sheet* should be used in tandem with this standard to help students use the appropriate formula when solving stand-alone problems or problems in context.

Mathematical Reasoning and Connections: Students must understand that the Pythagorean Theorem is used to determine the measure of any one of the three sides of a right triangle when the measures of the other two sides are known. Students should understand the connection between the Pythagorean Theorem and the Converse of the Pythagorean Theorem through proof and reasoning.

- Connect back to the Pythagorean Theorem. If two sides of a right triangle are known, those values can be substituted into the theorem to determine the missing side.

In a right triangle with legs a and b , and hypotenuse c :

$$a^2 + b^2 = c^2$$

In order to use the Pythagorean Theorem, students must know for certain that the triangle has a 90-degree angle. This reasoning is understood as – **If** a right triangle has legs a and b and hypotenuse c , **then** $a^2 + b^2 = c^2$. The order of this (conditional) statement is important to establish the connection to the converse.

- In the Pythagorean Theorem, the hypothesis (the part after the "If") is that it is a right triangle with legs a and b and hypotenuse, c . The conclusion (the part after the "then") is that a -squared plus b -squared equals c -squared. The converse is written in the reverse order – **If** $a^2 + b^2 = c^2$, **then** the triangle is a right triangle. The Converse of the Pythagorean Theorem states that if the square of the length of the hypotenuse equals the sum of the squares of the legs in a triangle, then the triangle is a right triangle. This can be used to determine whether a triangle is a right triangle given the measures of its three sides.
- When the converse is used, all three sides of the triangle will be known. If it is a right triangle, the longest side would be the hypotenuse. Students should choose the largest number for c . The smaller two numbers will be a and b . After substituting the values, students should recognize that if both sides of the equation are the same number, then the triangle is a right triangle. If the numbers are different, it is not a right triangle.
- Students in Grade 8 should be exposed to problems involving radicals when working with the Pythagorean Theorem. Consider the following example:

Select two sets of measurements that could each be the side lengths of a right triangle.

- 6 in., 7 in., 8 in.
- 1 m, 1 m, $\sqrt{2}$ m
- 7 ft, 24 ft, 25 ft
- $8\frac{1}{2}$ cm, $8\frac{1}{2}$ cm, $8\frac{1}{2}$ cm
- $\sqrt{3}$ mm, $\sqrt{4}$ mm, $\sqrt{5}$ mm

Students should select the measurements 1m, 1m, $\sqrt{2}$ m and 7ft, 24ft, 25ft as possible side lengths of a right triangle.

- Students can use an altitude drawn to the hypotenuse of a right triangle to prove the Pythagorean Theorem as pictured below.

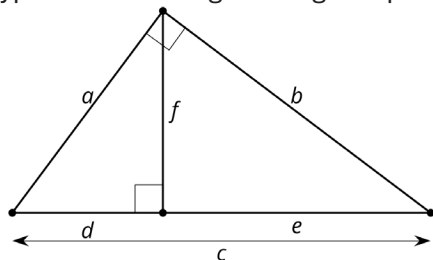

- Proportionality can be used to show that all three triangles are similar. Because the triangles are similar, corresponding side lengths are in the same proportion.

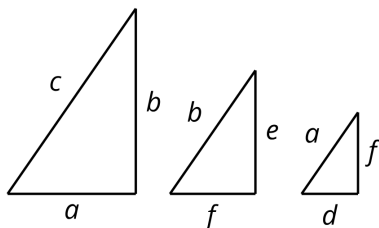

Because the largest triangle is similar to the smaller triangle, $\frac{c}{a} = \frac{a}{d}$, and the largest triangle is similar to the middle triangle, $\frac{c}{b} = \frac{b}{e}$, students can rewrite these equations as $a^2 = cd$ and $b^2 = ce$. Add the equations to get that $a^2 + b^2 = cd + ce$ or $a^2 + b^2 = c(d + e)$.

From the original diagram, it can be observed that $d + e = c$, so $a^2 + b^2 = (c)(c)$ or $a^2 + b^2 = c^2$. By using the Pythagorean Theorem, teachers can help students to describe a triangle's angles without ever drawing it. For example, a triangle with side lengths 8, 15, and 17 is right because $17^2 = 8^2 + 15^2$. A triangle with sides lengths 8, 15, and 18 is obtuse because $18^2 > 8^2 + 15^2$. A triangle with side lengths 8, 15, and 16 is acute because $16^2 < 8^2 + 15^2$.

Concepts and Connections

CONCEPTS

Analyzing and describing geometric objects, the relationships and structures among them, or the space that they occupy can be used to classify, quantify, measure, or count one or more attributes.

CONNECTIONS

- Within the grade level/course:*
 - 8.NS.1 – The student will compare and order real numbers and determine the relationships between real numbers.

- 8.MG.5 – The student will solve area and perimeter problems involving composite plane figures, including those in context.
- *Vertical Progression:*
 - G.TR.1 – The student will determine the relationships between the measures of angles and lengths of sides in triangles, including problems in context.
 - G.TR.3 – The student will, given information in the form of a figure or statement, prove and justify two triangles are similar using direct and indirect proofs, and solve problems, including those in context, involving measured attributes of similar triangles.
 - G.TR.4 – The student will model and solve problems, including those in context, involving trigonometry in right triangles and applications of the Pythagorean Theorem.
- *Digital Learning Integration:*
 - 6-8 CT.B. Students find or organize data and use appropriate technologies to interpret, analyze, and represent data to construct models, predict outcomes, solve problems, and make evidence-based decisions.

ACROSS CONTENT AREAS

Reference 8.MG.1

Resources to Support Local Curriculum

- A list of approved textbooks and instructional materials is posted on the VDOE [website](#).
- [Middle School Mathematics Formula Sheet](#) (PDF)

8.MG.5

The student will solve area and perimeter problems involving composite plane figures, including those in context.

Students will demonstrate the following Knowledge and Skills:

- Subdivide a plane figure into triangles, rectangles, squares, trapezoids, parallelograms, circles, and semicircles. Determine the area of subdivisions and combine to determine the area of the composite plane figure.
- Subdivide a plane figure into triangles, rectangles, squares, trapezoids, parallelograms, and semicircles. Use the attributes of the subdivisions to determine the perimeter of the composite plane figure.
- Apply perimeter, circumference, and area formulas to solve contextual problems involving composite plane figures.

Understanding the Standard

- A plane figure is any two-dimensional shape that can be drawn in a plane.
- A composite figure is any figure that can be subdivided into two or more shapes.

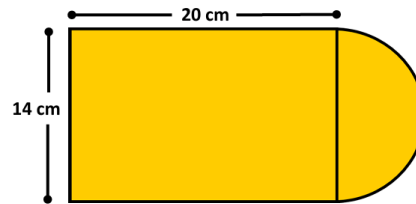

- The perimeter is the path or distance around any plane figure. The perimeter of a circle is called the circumference.
- The area is the surface included within a plane figure.
- The area of a composite figure can be found by subdividing the figure into triangles, rectangles, squares, trapezoids, parallelograms, circles, and semicircles, calculating their areas, and combining the areas together by addition and/or subtraction based upon the given composite figure.
- In the example below, the composite figure is composed of a square and an equilateral triangle. The side length of the square is 15 inches. Congruent sides and right angles are shown with geometric notation. The area of the square can be determined by using the formula $A = s^2$, therefore $A = 15(15)$, or 15^2 which is equal to 225 in. The area of the triangle can be determined by using the formula $A = \frac{1}{2}bh$, therefore $A = 7.5(15)$ or 112.5 in. The area of the composite figure can be determined by adding the area of the square (225 in) and the area of the triangle (112.5 in) together for a total area of 337.5 in.

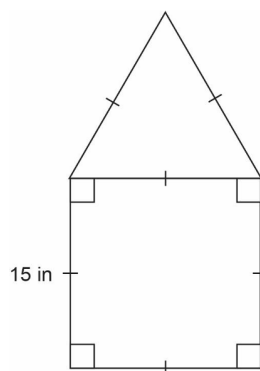

- The formula for the area of a rectangle is one of the first that is developed and is usually given as $A = l \cdot w$, or “area equals length times width”. Thinking ahead, an equivalent but more unifying idea is $A = b \cdot h$, or “area equals *base* times *height*”. The base-times-height formulation can be generalized to all parallelograms (not just rectangles) and is helpful when students are developing the area formulas for triangles and trapezoids in Grade 6.
- Any side of a figure can be called a *base*. For each base that a figure has, there is a corresponding *height*. The height is the perpendicular distance to the base. Regardless of which side is considered the base, the same area is generated through the use of the commutative property.
- Furthermore, the same approach can be extended to three dimensions. For example, the volume of a rectangular prism can be found by multiplying *length times width times height* (as in the formula $V = l \cdot w \cdot h$), or by multiplying the *area of the base* (B) times the *height* (h) (as in the formula $V = Bh$). Volumes of cylinders are given in terms of the *area of the base* (B) times the *height* (h), or $V = Bh$. Therefore, base times height connects a large family of formulas that otherwise must be mastered independently.
- The area of a triangle is computed by multiplying the measure of its base by the measure of its height and dividing the product by 2 or multiplying by one-half ($A = \frac{bh}{2}$ or $A = \frac{1}{2}bh$).

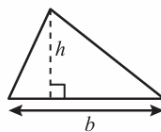

$$A = \frac{1}{2}bh$$

- The area of a rectangle is computed by multiplying the lengths of two adjacent sides ($A = lw$ or $A = bh$).

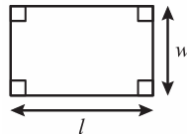

$$A = lw$$

- The area of a square is computed by multiplying the length of a side by itself ($A = s \cdot s$ or $A = s^2$).

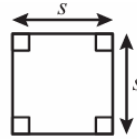

$$A = s^2$$

- The area of a trapezoid is computed by taking the average of the measures of the two bases and multiplying this average by the height ($A = \frac{1}{2}h(b_1 + b_2)$). A trapezoid can be considered a composite figure composed of triangle(s) and a rectangle.

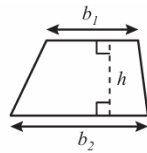

$$A = \frac{1}{2}h(b_1 + b_2)$$

- The area of a parallelogram is computed by multiplying the measure of its base by the measure of its height ($A = bh$). A parallelogram can be considered a composite figure composed of two triangles and a rectangle or two triangles.

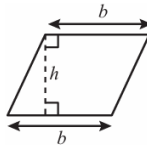

$$A = bh$$

- The area of a circle is computed by multiplying pi times the radius squared ($A = \pi r^2$).
- The circumference of a circle is found by multiplying pi by the diameter or multiplying pi by 2 times the radius ($C = \pi d$ or $C = 2\pi r$).

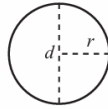

$$C = 2\pi r$$
$$C = \pi d$$
$$A = \pi r^2$$

Pi

$$\pi \approx 3.14$$
$$\pi \approx \frac{22}{7}$$

- The area of a semicircle is half the area of a circle with the same diameter or radius.

Skills in Practice

While the five process goals are expected to be embedded in each standard, the Skills in Practice highlight the most prevalent process goals in relation to the content presented.

Mathematical Problem Solving:

- Stress that there are four steps to solving contextual problems related to solving problems involving composite figures: distinguishing which combination of formulas should be used based on the shape(s) given, writing the formula(s), substituting the values, and solving including proper units. Care must be taken to have students label each figure creating the composite, including sides defining each shape.
- The *Middle School Mathematics Formula Sheet* should be used in tandem with this standard to help students use the appropriate formula when solving stand-alone problems or problems in context.
- Common challenges present while students determine the perimeter or area of composite figures when solving problems –
 - Students may not identify the basic shapes (or portions of shapes) that make up a composite figure.
 - Students may not know if a shape has been added or subtracted from the composite figure.
 - Students may not recognize the formula that defines the shape that makes up the composite figure.

Mathematical Reasoning:

- Students must understand that when solving contextual problems, they must look for essential vocabulary to determine whether the problem requires the application of area or perimeter. Contexts such as putting up a fence (perimeter) or painting a figure (area) are not always explicitly written in the phrasing like “find the perimeter or area of x figure.” Therefore, students should have exposure to problems that are in context as these represent real-world applications.
- As students determine the perimeter or area of composite figures, it is important for them to clearly apply markings to (or color-code) figures to ensure that each dimension is accounted for. An example with common errors is as follows –

- Find the area and perimeter of the composite figure:

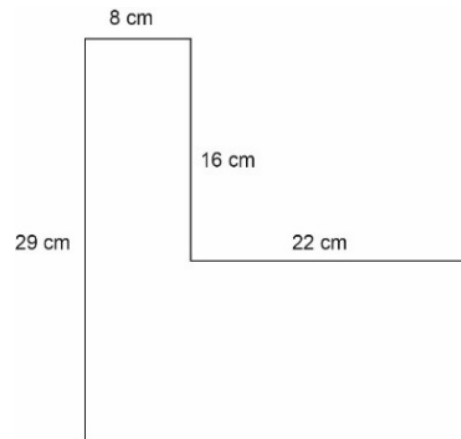

Area: A common error a student may make is attempting to find the area using only given measures and not calculating for missing side lengths. This may indicate a need to review identifying shapes used to create composite figures. It might be helpful for students to draw the two rectangles separately and label their side lengths. Teachers are encouraged to provide hands-on manipulatives, such as geoboards or pattern blocks, and allow students to create composite figures. Another common error a student may make is determining that the vertical missing side is 16 centimeters. This may indicate that a student did not take the difference of 29 and 16 but assumed that the two shorter, vertical sides are congruent. It might be helpful for a student to draw the figure to scale on grid paper, allowing them to count the side lengths. Teachers are encouraged to show students at least two methods for calculating the missing side lengths: drawing the figure on grid paper, and performing the needed calculation based on the position of the missing side.

Perimeter: A common error a student may make is adding the four given measures and calculating the perimeter to be 75 centimeters. This may indicate a need to review vocabulary associated with two-dimensional figures and perimeter. It might be helpful for students to highlight the entire perimeter of the composite figure before beginning the calculation.

- When determining the area between a shaded and unshaded region, students must again be sure to label each figure (ensure all dimensions are accounted for) and be reminded to take the difference of each of the regions to completely solve the problem. An example with common errors is as follows –

A landscaper was hired to fertilize the yard represented by the shaded region shown below. How much fertilizer will he need

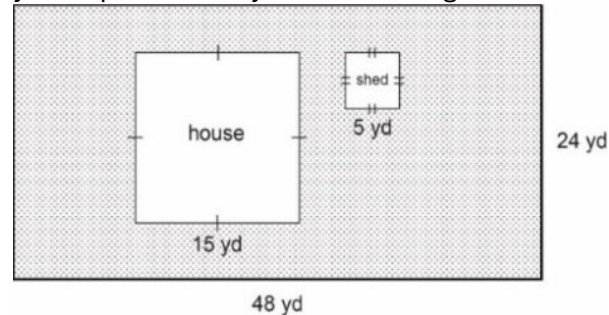

A common error a student may make is adding the areas of the house and shed, rather than subtracting the areas of the house and shed from the area of the yard. This may indicate that a student does not understand negative space. It might be helpful for students to identify the shapes, the necessary formulas, and whether the areas of the shapes will be added or subtracted before beginning the problem. Teachers are encouraged to provide students with hands-on practice that allows a student to see the change in area once a shape has been cut out of another shape.

A common error a student may make is calculating the perimeter, rather than the area. This may indicate a need to review vocabulary associated with area and perimeter. Teachers are encouraged to facilitate a discussion where students can list words that indicate area and perimeter. Teachers are also encouraged to provide opportunities for students to read and sort practical problems that utilize area and perimeter, without solving them.

Concepts and Connections

CONCEPTS

Analyzing and describing geometric objects, the relationships and structures among them, or the space that they occupy can be used to classify, quantify, measure, or count one or more attributes.

CONNECTIONS

- *Within the grade level/course:*
 - 8.MG.2 – The student will investigate and determine the surface area of square-based pyramids and the volume of cones and square-based pyramids.
 - 8.MG.4 – The student will apply the Pythagorean Theorem to solve problems involving right triangles, including those in context.
- *Vertical Progression:*
 - 6.MG.1 – The student will identify the characteristics of circles and solve problems, including those in context, involving circumference and area.

- 6.MG.2 – The student will reason mathematically to solve problems, including those in context, that involve the area and perimeter of triangles and parallelograms.
- G.PC.2 – The student will verify relationships and solve problems involving the number of sides and angles of convex polygons.
- G.PC.3 – The student will solve problems, including those in context, by applying properties of circles.
- *Digital Learning Integration:*
 - 6-8 CT.B. Students find or organize data and use appropriate technologies to interpret, analyze, and represent data to construct models, predict outcomes, solve problems, and make evidence-based decisions.

ACROSS CONTENT AREAS

Reference 8.MG.1

Resources to Support Local Curriculum

- A list of approved textbooks and instructional materials is posted on the VDOE [website](#).
- [Middle School Mathematics Formula Sheet](#) (PDF)

Probability and Statistics

In K-12 mathematics, probability and statistics introduce students to the concepts of uncertainty and data analysis. Probability involves understanding the likelihood of events occurring, often using concepts such as experiments, outcomes, and the use of fractions and percentages. The formal study of probability begins in Grade 4. Statistics focuses on collecting, organizing, and interpreting data and includes a basic understanding of graphs and charts. Probability and statistics help students analyze and make sense of real-world data and are fundamental for developing critical thinking skills and making informed decisions using data.

In Grade 8, students learn that the world can be investigated through posing questions and collecting, representing, analyzing, and interpreting data to describe and predict events and real-world phenomena. At this grade level, students use statistical investigation to determine the probability of independent and dependent events; and apply the data cycle (formulate questions; collect or acquire data; organize and represent data; and analyze data and communicate results) with a focus on boxplots and scatterplots.

8.PS.1

The student will use statistical investigation to determine the probability of independent and dependent events, including those in context.

Students will demonstrate the following Knowledge and Skills:

- a) Determine whether two events are independent or dependent and explain how replacement impacts the probability.
- b) Compare and contrast the probability of independent and dependent events.
- c) Determine the probability of two independent events.
- d) Determine the probability of two dependent events.

Understanding the Standard

- The probability of two events occurring can be represented as a ratio or the equivalent fraction, decimal, or percent.
- The probability of an event occurring is a ratio between 0 and 1. A probability of zero means the event will never occur (i.e., it is impossible). A probability of one means the event will always occur (i.e., it is certain).
- Two events are either dependent or independent.
- If the outcome of one event does not influence the occurrence of the other event, they are called independent. If two events are independent, then the probability of the second event does not change regardless of whether the first occurs. For example:
 - The first roll of a number cube does not influence the second roll of the number cube
 - Spinning a spinner and rolling a number cube

- Flipping a coin and selecting a card
- If two events occur with replacement, the outcome of one event does not influence the occurrence of the other event. Thus, the two events are independent because the probability of the second event does not change regardless of whether the first occurs. Some examples include:
 - Choosing a card from a deck, replacing the card, and selecting again
 - Choosing a marble from a bag, replacing the marble, and selecting again
- The probability of two independent events is found by multiplying the probability of the first event by the probability of the second event or using the following formula: $P(A \text{ and } B) = P(A) \cdot P(B)$. For example:
 - When simultaneously rolling a six-sided number cube and flipping a coin, what is the probability of rolling a 3 on the cube and getting a heads on the coin?

$$P(3 \text{ and heads}) = \frac{1}{6} \cdot \frac{1}{2} = \frac{1}{12}$$

- There is a bag with 8 blue marbles, 7 green marbles, and 5 red marbles. What is the probability of selecting a blue marble, replacing it, then selecting a green marble?

$$P(\text{blue and green}) = P(\text{blue}) \cdot P(\text{green after blue is replaced})$$

$$P(\text{blue and green}) = \frac{8}{20} \cdot \frac{7}{20} = \frac{56}{400} = \frac{7}{50}$$

- If the outcome of one event has an impact on the outcome of the other event, the events are called dependent. If events are dependent, then the second event is considered only after the first event has already occurred. For example:
 - If two events occur without replacement, the outcome of the first event has an impact on the outcome of the second event. Thus, the probability of the second event changes as a result of the first event occurring. Some examples include:
 - Choosing a blue card from a set of nine different colored cards that have a total of four blue cards and not replacing the blue card back in the set before selecting a second card. The chance of selecting a blue card the second time is diminished because there are now only three blue cards remaining in the set.
 - Choosing two marbles from a bag but not replacing the first marble after selecting it.
- The probability of two dependent events is found by multiplying the probability of the first event by the probability of the second event *after* the first event has occurred or using the following formula: $P(A \text{ and } B) = P(A) \cdot P(B \text{ after } A)$. For example:
 - There is a bag containing a blue ball, a red ball, and a yellow ball. What is the probability of picking a blue ball out of the bag on the first pick, and then, without replacing the blue ball in the bag, picking a red ball on the second pick?

$$P(\text{blue and red}) = P(\text{blue}) \cdot P(\text{red after blue}) = \frac{1}{3} \cdot \frac{1}{2} = \frac{1}{6}$$

- You are holding all of the jacks, queens, and kings in a deck of cards. What is the probability of choosing a queen on the first pick, and then, without replacing the queen in the pile, choosing a king on the second pick?

$$P(\text{queen and king}) = P(\text{queen}) \cdot P(\text{king after queen}) = \frac{4}{12} \cdot \frac{4}{11} = \frac{16}{132} = \frac{4}{33}$$

Skills in Practice

While the five process goals are expected to be embedded in each standard, the Skills in Practice highlight the most prevalent process goals in relation to the content presented.

Mathematical Reasoning:

- To be successful with this standard, students must know the difference between independent and dependent events, including in context, and how replacement impacts these events. Simply, two or more events are considered independent if the results of the events following the first event are not affected by the result of any of the preceding events. Events are dependent when the occurrence of one event affects the probability of the occurrence of the other. Dependent events are affected by the outcomes that have already occurred previously. If one event is changed, then another is likely to differ. Statistical investigations (trials or experiments) help to solidify students' understanding of these concepts, similar to investigations conducted in Grade 7 where students examined theoretical and experimental probabilities.
- Students should have the opportunity to engage in games or simulations of chance to explore independent and dependent events, to include the application of the algorithm to determine results. For example –
 - **Independent Events:** To find the probability, or odds, of independent events, multiply the probability of each of the individual events. This can be written as: $P(A \text{ and } B) = P(A) \times P(B)$. Consider the following scenario –

There is a bag with 5 green marbles, 3 blue marbles, and 2 red marbles. For each event, one marble is removed from the bag, the color is recorded, and then the marble is replaced. Then another marble is chosen. What is the probability that the first marble is red, and the second marble is green?

Because the first marble is replaced, the number of marbles drawn (10) does not change from the first drawing to the second drawing. That makes each drawing an independent event.

$$P(A \text{ and } B) = P(A) \times P(B)$$

$$P(\text{red then green}) = P(\text{red}) \times P(\text{green})$$

$$\begin{aligned}
 &= \frac{2}{10} \times \frac{5}{10} \\
 &= \frac{10}{100} \\
 &= \frac{1}{10}
 \end{aligned}$$

As students complete their investigations, encourage them to summarize their understanding, to include numerical representations of probability, which can take the form of a fraction, decimal, or percent. Per the example, students may say, “The odds are one in ten (.10 or 10%) that the first draw will be a red and the second draw will be green.”

- **Dependent Events:** When two events, A and B , are dependent, the probability of the outcome can be written as: $P(A \text{ and } B) = P(A) \times P(A|B)$. In action, with the same bag of marbles addressed above –

There is a bag with 5 green marbles, 3 blue marbles, and 2 red marbles. When a marble is drawn from the bag, it is not replaced. What is the probability that a red marble is drawn first and then a green marble?

$$P(\text{red then green}) = P(\text{red}) \times P(\text{green} \mid \text{red first})$$

The probability of the first event happening is the same as if it were an independent event. The second probability is now 5 out of 9, since the bag has only 9 marbles left in it.

$$\begin{aligned}
 P(\text{red then green}) &= P(\text{red}) \times P(\text{green} \mid \text{red first}) \\
 &= \frac{2}{10} \times \frac{5}{9} \\
 &= \frac{10}{90} \\
 &= \frac{1}{9}
 \end{aligned}$$

As students complete their investigations, encourage them to summarize their understanding, to include numerical representations of probability, which can take the form of a fraction, decimal, or percent.

- Continue statistical investigations for various combinations and recalculate the probabilities. Conduct experiments involving chance events. Assigning probabilities to these events will help show the effects of previous occurrences and encourage the use of probability terms ‘if’, ‘given’, ‘and’ and so on. These types of experiments will also help students see whether the occurrence of an event will influence the occurrence of another. As the rounds continue, have students engage in discourse to describe what changes they observe.

Mathematical Connections: Hands-on simulations where students calculate the probability of winning a game and playing a game give context and meaning to the calculations as students learn about independent and dependent events. Students develop problem solving strategies as they use mathematics to represent meaningful situations. They practice fluency skills as they calculate answers efficiently and recognize ways of answering questions. For example –

- Provide pairs of students with a container with two red and four blue ribbons/counters/cubes. Ask students to read the given scenario and play the game a few times. Taking turns, they each take a ribbon from the container without replacing. One player wins if both are the same color; if they are different colors, the other player wins.

Gillian and Scott decided to play a game. They put two red and four blue ribbons in a box. They each pick a ribbon from the box without looking and without replacing them. Scott wins if the two ribbons are the same color and Gillian wins if the two ribbons are different colors.

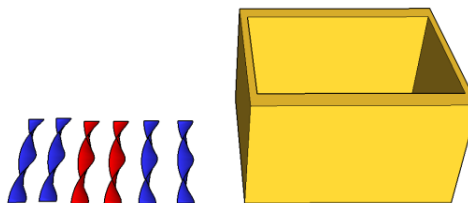

As students engage in the game ask, *“Is the game fair? If not, how many ribbons of each color are needed in the box to make it a fair game? Is there more than one way to make a fair game?”*

After playing the game ask students to investigate the probability of the game by answering the following questions: *“How can you decide if the game is fair? How many times do you think we need to play the game, to be confident of the likelihood of winning? Are there efficient systems for recording the different possible combinations? Can you justify your conclusions?”* As a class, discuss the results obtained.

Concepts and Connections

CONCEPTS

The world can be investigated through posing questions and collecting, representing, analyzing, and interpreting data to describe and predict events and real-world phenomena.

CONNECTIONS

- *Within the grade level/course:*

- 8.PS.2 – The student will apply the data cycle (formulate questions; collect or acquire data; organize and represent data; and analyze data and communicate results) with a focus on boxplots.
- 8.PS.3 – The student will apply the data cycle (formulate questions; collect or acquire data; organize and represent data; and analyze data and communicate results) with a focus on scatterplots.
- *Vertical Progression:*
 - 7.PS.1 – The student will use statistical investigation to determine the probability of an event and investigate and describe the difference between the experimental and theoretical probability.
 - A2.ST.3 – The student will compute and distinguish between permutations and combinations.
- *Digital Learning Integration:*
 - 6-8 CT.A. Students create, identify, explore, and solve problems using technology-assisted methods such as data analysis, modeling, or algorithmic thinking.

ACROSS CONTENT AREAS [THEME – USING DATA]

- *Computer Science:*
 - Data and Statistics concepts include storing and process data; analyzing large datasets; and designing graphs and charts.
 - Statistics and Probability highlights include artificial intelligence and machine learning – probability is used in decision making algorithms; randomized algorithms – randomized sorting algorithms; and cybersecurity and encryption – cryptographic key generation.
- *Physical Science:*
 - PS.2 The student will investigate and understand that matter is composed of atoms. To meet this standard, students are expected to analyze a heating curve.
 - PS.3 The student will investigate and understand that matter has properties and is conserved in chemical and physical processes. To meet this standard, students are expected to plan and conduct an investigation to separate mixtures; determine the relationship between mass and volume; and determine if a chemical change has occurred.
 - PS.5 The student will investigate and understand that energy is conserved. To meet this standard, students are expected to interpret graphs regarding kinetic energy; plan and conduct investigations about energy transformation and thermal energy; and design a device for thermal energy transfer.
 - PS. 6 The student will investigate and understand that waves are important in the movement of energy. To meet this standard, students are expected to plan and conduct an investigation on sound waves and light waves and to analyze graphs to determine the effect on sound waves.

- PS.7 The student will investigate and understand that electromagnetic radiation has characteristics. To meet this standard, students are expected to plan and conduct an investigation on interaction of visible light with mirror and lenses.
- PS.8 The student will investigate and understand that work, force, and motion are related. To meet this standard, students are expected to plan and conduct investigation on the change of motion and analyze data on relationships of frame. Students are also expected to analyze calculations of work and power.
- PS.9 The student will investigate and understand that there are basic principles of electricity and magnetism. To meet this standard, students are expected to plan and conduct an investigation to determine factors of electric and magnetic forces.

Resources to Support Local Curriculum

- A list of approved textbooks and instructional materials is posted on the VDOE [website](#).
- [Middle School Mathematics Formula Sheet](#) (PDF)

8.PS.2

The student will apply the data cycle (formulate questions; collect or acquire data; organize and represent data; and analyze data and communicate results) with a focus on boxplots.

Students will demonstrate the following Knowledge and Skills:

- a) Formulate questions that require the collection or acquisition of data with a focus on boxplots.
- b) Determine the data needed to answer a formulated question and collect the data (or acquire existing data) using various methods (e.g., observations, measurement, surveys, experiments).
- c) Determine how statistical bias might affect whether the data collected from the sample is representative of the larger population.
- d) Organize and represent a numeric data set of no more than 20 items, using boxplots, with and without the use of technology.
- e) Identify and describe the lower extreme (minimum), upper extreme (maximum), median, upper quartile, lower quartile, range, and interquartile range given a data set, represented by a boxplot.
- f) Describe how the presence of an extreme data point (outlier) affects the shape and spread of the data distribution of a boxplot.
- g) Analyze data represented in a boxplot by making observations and drawing conclusions.
- h) Compare and analyze two data sets represented in boxplots.
- i) Given a contextual situation, justify which graphical representation (e.g., pictographs, bar graphs, line graphs, line plots/dot plots, stem-and-leaf plots, circle graphs, histograms, and boxplots) best represents the data.
- j) Identify components of graphical displays that can be misleading.

Understanding the Standard

- Students should explore the entire data cycle with a question and set of data that has been collected or acquired. Student reflection should occur throughout the data cycle. The data cycle includes the following steps: formulating questions to be explored with data, collecting or acquiring data, organizing and representing data, and analyzing and communicating results.

Data Cycle
Grade K-Algebra 2

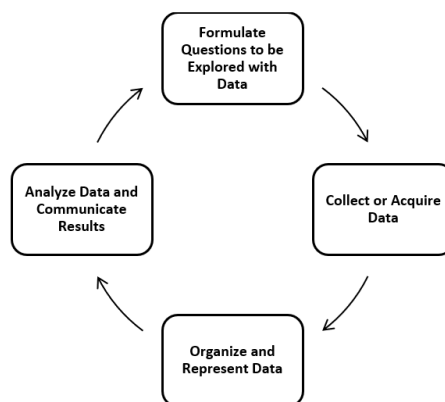

- To collect data for any problem situation, an experiment can be designed, a survey can be conducted, or other data-gathering strategies can be used. The data can be organized, displayed, analyzed, and interpreted to solve the problem.
- The teacher can provide data sets in addition to students engaging in their own data collection or acquisition.
- A population is the entire set of individuals or items from which data is drawn for a statistical study.
- A sample is a data set that you obtain from a subset that represents an entire population. This data set can be used to make reasonable assumptions about the whole population.
- Sampling is the process of selecting a suitable sample, or a representative part of a population, for the purpose of determining characteristics of the whole population.
- An example of a population would be the entire student body at a school, whereas a sample might be only one grade level in the entire student body at a school. A sample may or may not be representative of the population as a whole. Questions to consider when determining whether an identified sample is representative of the population include:
 - What is the target population of the formulated question?
 - Who or what is the subject or context of the question?
- A random sample is one in which each member of the population has an equal chance of being selected. Random samples can be used to ensure that the sample is representative of the population and to avoid bias.
- Sample size refers to the number of participants or observations included in a study. Statistical data may be more accurate, and outliers may be more easily identified with larger sample sizes.
- Examples of questions to consider in building good samples:

- What is the context of the data to be collected?
- Who is the audience?
- What amount of data should be collected?
- Bias may limit the degree to which accurate conclusions can be drawn. Errors in collecting and organizing the data may also contribute to bias.
- Bias may influence data analysis and may result in misleading generalizations and only support one opinion or view.
- Sampling bias may occur when members of a population are systematically more likely to be chosen over other members of the same population. In other words, sampling bias does not ensure proper randomization.
- Numerical univariate data refers to information gathered around a single characteristic. Examples include scores on assessments, distance to school, time spent looking at social media, hours spent practicing a hobby, etc.
- A boxplot (box-and-whisker plot) is a convenient and informative way to represent single-variable (univariate) data.
- A boxplot uses a rectangle to represent the middle half of a set of data and lines (whiskers) at both ends to represent the remainder of the data. The median is marked by a vertical line inside the rectangle.
- The five critical points in a boxplot, commonly referred to as the five-number summary, are lower extreme (minimum), lower quartile (Q1), median (Q2), upper quartile (Q3), and upper extreme (maximum). Each of these points represents the bounds for the four quartiles. In the example below, the lower extreme is 5, the lower quartile is 8, the median is 14, the upper quartile is 17, and the upper extreme is 19.

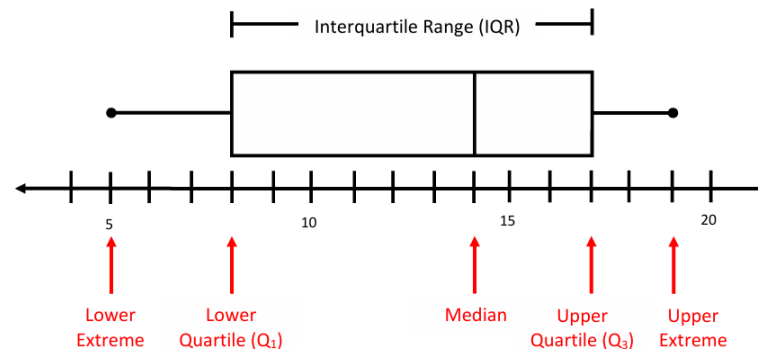

- A quartile is a value, a position on the number line, that separates the data into four sections. These values provide information about what approximate percent of the data falls below that value. The lower quartile is the median of the data points to the left of the median and is referred to as the 25th percentile; the median is referred to as the 50th percentile; and the upper quartile is the median of the data points to the right of the median and is referred to as the 75th percentile.

- To determine the values of the five critical points in a boxplot, first the data should be written in ranked order. Then, the five points can be found as follows:
 - Lower extreme: the smallest data point (minimum)
 - Lower quartile (Q1): the middle value of the data points to the left of the median (Note: if there are an odd number of data values, the median should not be considered when calculating the lower quartile)
 - Median (Q2): if there are an odd number of data points, the median is the middle value; if there are an even number of data points, the median is the arithmetic average of the two middle values
 - Upper quartile (Q3): the middle value of the data points to the right of the median (Note: if there are an odd number of data values, the median should not be considered when calculating the upper quartile)
 - Upper extreme: the largest data point (maximum)

- Example – Calculate the median, lower, and upper quartile for the following data set:

3 5 6 7 8 9 11 13 13

Median: 8 Lower Quartile: 5.5 Upper Quartile: 12

- The range is the difference between the upper extreme and the lower extreme.
- The interquartile range (IQR) is the difference between the upper quartile and the lower quartile. Using the example data set above, the range is 10 or $13 - 3$. The interquartile range is 6.5 or $12 - 5.5$.
- Boxplots are effective at giving an overall impression of the shape, center, and spread of the data. They do not show a distribution in as much detail as a stem-and-leaf plot or a histogram.
- A boxplot allows for quick analysis of a set of data by identifying key statistical measures (median and range) and major concentrations of data.
- Technology, such as graphing utilities and spreadsheets, can be used to construct box plots.
- In the pulse rate example, shown below, many students incorrectly interpret that longer sections contain more data and shorter ones contain less. It is important to remember that roughly the same amount of data is in each section. The numbers in the left whisker (lowest of the data) are spread less widely than those in the right whisker.

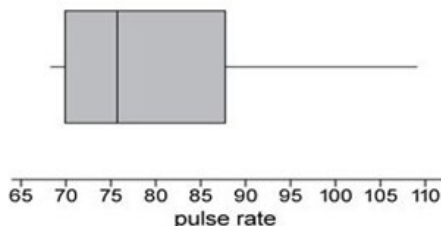

- Boxplots are useful when evaluating and describing spread of data, representing data by percentages, and comparing information about two numerical data sets. The example below compares the test scores for a college class offered at two different times.

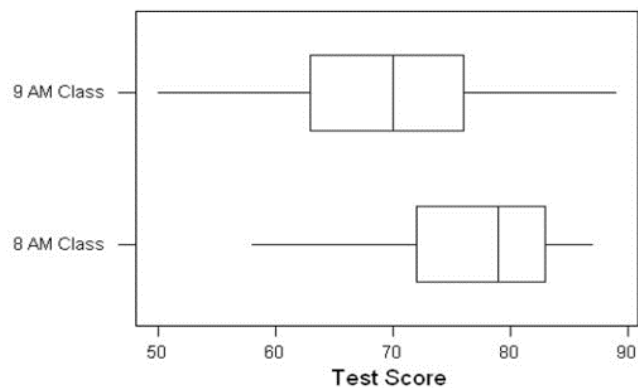

- Using these boxplots, possible interpretations could include, but are not limited to:
 - The 8 am class had a greater median test score than the 9 am class.
 - The highest scoring student was in the 9 am class.
 - The probability of selecting a student who passed the test is greater in the 8 am class than the 9 am class.
 - If a passing score is 70%, then 75% of the students in the 8 am class passed the test.
 - More students failed in the 9 am class if the passing score is 70%.
 - The scores in the 8 AM class are more consistent because they are clustered more closely together.
- An outlier can be identified by sorting the data in ascending order. A data value that is an abnormal distance relative to the other values in the data set is an outlier. It represents a value that "lies outside" (is much smaller or larger than) most of the other values in a set of data. Outliers have a greater effect on the mean and range of a data set but have lesser effect on the median or mode. A boxplot that has a long whisker indicates there is an outlier in the data set. In grade 8 it is not necessary for students to identify outliers using an algorithm.
- In previous grades, students had experience with pictographs, bar graphs, line graphs, line plots, stem-and-leaf plots, circle graphs, and histograms. In Grade 8, students are not expected to construct these graphs.
 - A pictograph is used to show categorical data. Pictographs are used to show frequency and compare categories.
 - A bar graph is used for categorical data and is used to show comparisons between categories.

- A line graph is used to show how numerical data changes over time.
- A line plot (dot plot) provides an ordered display of all values in a data set and shows the frequency of data on a number line. Line plots are used to show the spread of the data, to include clusters (groups of data points) and gaps (large spaces between data points), and quickly identify the range, mode, and any extreme data values.
- A stem-and-leaf plot is used for discrete numerical data and is used to show frequency of data distribution. A stem-and-leaf plot displays the entire data set and provides a picture of the distribution of data.
- A circle graph is used for categorical and discrete numerical data. Circle graphs are used to show a relationship of the parts to a whole. Every element of the data set is not preserved when representing data in a circle graph.
- A histogram is a form of bar graph in which the categories are consecutive and equal intervals. The length or height of each bar is determined by the number of data elements (frequency) falling into a particular interval.
- Different types of graphs can be used to display categorical and numerical data. The way data is displayed is often dependent on what someone is trying to communicate.
- Students would benefit from exploring previously taught graphical representations when justifying how to best represent data clearly and accurately. Comparing different types of representations (charts and graphs) provides an opportunity to learn how different graphs can show different things about the same data. Discussions around what information different graphs representing the same data provides is beneficial for determining which graphical representation best represents the data.
- Components of graphical displays of data that can be misleading include, but are not limited to:
 - manipulating the scale (e.g., not starting the scale at zero)
 - manipulating intervals that could exaggerate the distance between data points
 - omitting important information in titles and labels
 - omitting certain data points, including outliers
 - choosing a graphical display that does not best represent the data.

Skills in Practice

While the five process goals are expected to be embedded in each standard, the Skills in Practice highlight the most prevalent process goals in relation to the content presented.

Mathematical Communication: Students should be led to discussions of univariate and bivariate data. Boxplots represent univariate data. Here, students should ask questions in which they are considering gathering information around a single characteristic (e.g., scores on assessments, time spent looking at social media, hours spent on an activity). For boxplots, these data should be numerical (not categorical), where students look at the overall shape, center, and spread. Examples of questions students may consider in building good samples include:

- What is an appropriate amount of data?
- Who is the audience?
- What is the context of the data to be collected?
- Is the sample data representative of the larger population?

Mathematical Reasoning: Students should consider the following when analyzing boxplots –

- When representing general features of single variable data –
 - Is the sample representative of the population I am making conclusions about?
 - Am I interested in these overall features of the data: shape, center, spread?
 - Do I need details of individual data points? (If so, a boxplot is not the appropriate representation.)
- Data displays are intended to simplify—it is challenging to digest the raw data. However, most data displays will lose details.
 - Are there significant outliers that will skew the overall representation and potentially lead to misinterpretation or generalizations?
- The labels are key to communication.
 - What title and labels are necessary to clearly communicate?
 - What scale will show the appropriate features of the data?
- Some numerical summaries of quantitative data are more resistant than others to extreme data values, called outliers. Outliers can affect the values for various numerical summaries and may provide misleading information about characteristics of a distribution for quantitative data. As students reflect on the impact of outliers, guiding questions may include, *“Which summary measure of center – median or mean – will be more affected by outliers? Which summary measures of variability – range, interquartile range (IQR) – do you think will be the most affected by outliers?”*

Mathematical Representations: Graphs based on a division of the ordered data into equal-sized groups are useful for displaying distributions of quantitative data. At this grade, when representing boxplots, guide students in understanding the overall shape, distribution, and center of data. Boxplots are not useful for looking at individual data points and do not show how many data points are included in the data set. Boxplots help to analyze median and range and are impacted by outliers. Boxplots can be used to generally compare two sets of data using two different boxplots where the range and interquartile range can be found easily, and values are depicted – minimum, lower quartile, median, upper quartile, and maximum values.

Concepts and Connections

CONCEPTS

The world can be investigated through posing questions and collecting, representing, analyzing, and interpreting data to describe and predict events and real-world phenomena.

CONNECTIONS

- *Within the grade level/course:*
 - 8.PS.3 – The student will apply the data cycle (formulate questions; collect or acquire data; organize and represent data; and analyze data and communicate results) with a focus on scatterplots.
- *Vertical Progression:*
 - 7.PS.2 – The student will apply the data cycle (formulate questions; collect or acquire data; organize and represent data; and analyze data and communicate results) with a focus on histograms.
 - A.ST.1 – The student will apply the data cycle (formulate questions; collect or acquire data; organize and represent data; and analyze data and communicate results) with a focus on representing bivariate data in scatterplots and determining the curve of best fit using linear and quadratic functions.
- *Digital Learning Integration*
 - 6-8 CT.B. Students find or organize data and use appropriate technologies to interpret, analyze, and represent data to construct models, predict outcomes, solve problems, and make evidence-based decisions.

ACROSS CONTENT AREAS

Reference 8.PS.1

Resources to Support Local Curriculum

- A list of approved textbooks and instructional materials is posted on the VDOE [website](#).
- [Middle School Mathematics Formula Sheet](#) (PDF)
- Representing Data Using Boxplots Exemplar Mathematics Instructional Plan ([Word](#) | [PDF](#))

8.PS.3

The student will apply the data cycle (formulate questions; collect or acquire data; organize and represent data; and analyze data and communicate results) with a focus on scatterplots.

Students will demonstrate the following Knowledge and Skills:

- Formulate questions that require the collection or acquisition of data with a focus on scatterplots.
- Determine the data needed to answer a formulated question and collect the data (or acquire existing data) of no more than 20 items using various methods (e.g., observations, measurement, surveys, experiments).
- Organize and represent numeric bivariate data using scatterplots with and without the use of technology.
- Make observations about a set of data points in a scatterplot as having a positive linear relationship, a negative linear relationship, or no relationship.
- Analyze and justify the relationship of the quantitative bivariate data represented in scatterplots.
- Sketch the line of best fit for data represented in a scatterplot.

Understanding the Standard

- Students should explore the entire data cycle with a question and set of data that has been collected or acquired. Student reflection should occur throughout the data cycle. The data cycle includes the following steps: formulating questions to be explored with data, collecting or acquiring data, organizing and representing data, and analyzing and communicating results.

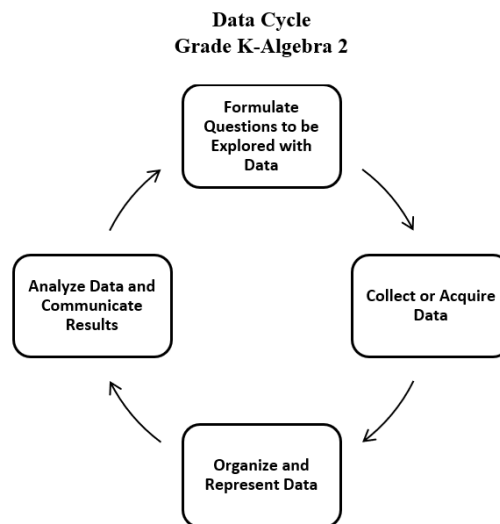

- To collect data for any problem situation, an experiment can be designed, a survey can be conducted, or other data-gathering strategies can be used. The data can be organized, displayed, analyzed, and interpreted to solve the problem.
- The teacher can provide data sets in addition to students engaging in their own data collection or acquisition.
- A scatterplot illustrates the relationship between two sets of numerical data represented by two variables (bivariate data). A scatterplot consists of points on the coordinate plane. The coordinates of a point represent the measures of the two attributes of the point.
- In a scatterplot, each point may represent an independent and dependent variable. The independent variable is graphed on the horizontal axis and the dependent is graphed on the vertical axis.
- Scatterplots can be used to predict linear trends and estimate a line of best fit.
- A line of best fit helps in making interpretations and predictions about the situation modeled in the data set. Lines and curves of best fit are explored more in Algebra 1 and used to make interpretations and predictions.
- A scatterplot can suggest various kinds of linear relationships between variables. Linear relationships may be positive (rising) or negative (falling). If the pattern of points slopes from lower left to upper right, it indicates a positive linear relationship between the variables being studied. If the pattern of points slopes from upper left to lower right, it indicates a negative linear relationship.
- No relationship: The position of the data values when graphed suggests that there is no definite positive or negative pattern established.
- Positive relationship: The position of the data values when graphed suggest that as one of the variables increases it has the same effect on the second variable. As variable 1 increases, variable 2 increases to indicate a positive linear relationship.
- Negative relationship: The position of the data values when graphed suggest that as one variable increases it has an opposite effect on the second variable. As variable 1 increase, variable 2 decreases to indicate a negative linear relationship.
- The following scatterplots illustrate how patterns in data values may indicate linear relationships.

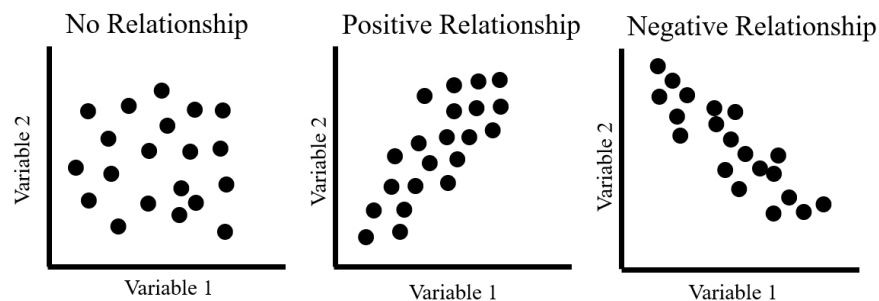

- A linear relationship between variables does not necessarily imply causation. For example, as the temperature at the beach increases, the sales at an ice cream store increase. If data were collected for these two variables, a positive linear relationship would

exist, however, there is no causal relationship between the variables (e.g., the temperature outside does not cause ice cream sales to increase, but there is a relationship between the two).

- The relationship between variables is not always linear and may be modeled by other types of functions that are studied in high school and college level mathematics.

Skills in Practice

While the five process goals are expected to be embedded in each standard, the Skills in Practice highlight the most prevalent process goals in relation to the content presented.

Mathematical Communication: Students should be led to discussions of univariate and bivariate data. Scatterplots represent bivariate data. Here, students should ask questions in which they are considering the relationship between two characteristics or variables. They are looking for trends in this relationship or looking to make a prediction based on the relationship (e.g., time and distance; age and height). For scatterplots, these data are numerical represented by two variables. Examples of questions students may consider in building good samples include:

- What is an appropriate amount of data?
- Who is the audience?
- What is the context of the data to be collected?

Mathematical Reasoning: Students should consider the following when analyzing scatterplots:

- Scatter plots are about the relationship between two variables –
 - Am I interested in the potential relationship between these two variables?
 - Do I want to see individual data points?
 - Am I interested in making predictions about these variables?
 - Does a line of best fit help me make predictions about this data?
 - Is there a correlation between the variables? What type?
- The labels are key to communication.
 - What title and labels are necessary to clearly communicate?
 - Should I draw a line of best fit to model the data?
- Investigating questions of relationships requires data collected on both variables (bivariate data). The analysis of bivariate data focuses on identifying and describing patterns in the covariability in the data. For a collection of bivariate data on two quantitative variables, a scatterplot is a useful graphical display for illustrating the covariability and for identifying the general direction and form of a relationship. A variety of numerical summaries are useful for characterizing various aspects of the relationship between

two quantitative variables. The line of best fit can be used to summarize the relationship and to make predictions for specified variables.

Mathematical Representations: At this grade, students will represent scatterplots. Scatterplots show individual data points, and help to identify a correlation or relationship between two variables. A line of best fit can be drawn to show trends in the data and to help make predictions based on the data. The relationship between the variables could be positive, negative, or have no correlation. The following scatterplots illustrate how patterns in data values may indicate linear relationships.

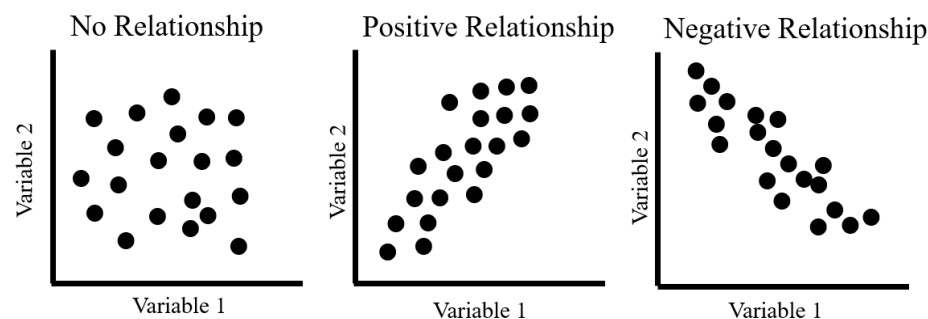

Concepts and Connections

CONCEPTS

The world can be investigated through posing questions and collecting, representing, analyzing, and interpreting data to describe and predict events and real-world phenomena.

CONNECTIONS

- *Within the grade level/course:*
 - 8.PS.2 – The student will apply the data cycle (formulate questions; collect or acquire data; organize and represent data; and analyze data and communicate results) with a focus on boxplots.
- *Vertical Progression:*
 - 7.PS.2 – The student will apply the data cycle (formulate questions; collect or acquire data; organize and represent data; and analyze data and communicate results) with a focus on histograms.
 - A.ST.1 – The student will apply the data cycle (formulate questions; collect or acquire data; organize and represent data; and analyze data and communicate results) with a focus on representing bivariate data in scatterplots and determining the curve of best fit using linear and quadratic functions.
- *Digital Learning Integration*

- 6-8 CT.B. Students find or organize data and use appropriate technologies to interpret, analyze, and represent data to construct models, predict outcomes, solve problems, and make evidence-based decisions.

ACROSS CONTENT AREAS

Reference 8.PS.1

Resources to Support Local Curriculum

- A list of approved textbooks and instructional materials is posted on the VDOE [website](#).
- [Middle School Mathematics Formula Sheet](#) (PDF)

Patterns, Functions, and Algebra

In K-12 mathematics, the patterns, functions, and algebra strand focuses on the recognition, description, and analysis of patterns, functions, and algebraic concepts. Students develop an understanding of mathematical relationships and represent these using symbols, tables, graphs, and rules. In later grades, students use models as they solve equations and inequalities and develop an understanding of functions. This strand is designed to develop students' algebraic thinking and problem-solving skills, laying the foundation for more advanced mathematical concepts.

In Grade 8, students will learn that proportional relationships can be described, and generalizations can be made using patterns, relations, and functions. Algebraic Equations and Inequalities can be used to represent and solve real world problems. At this grade level, students will represent, simplify, and generate equivalent algebraic expressions in one variable; and create and solve multistep linear equations and inequalities in one variable. Students will determine whether a given relation is a function, will determine the domain and range of a function, and will represent and solve problems using linear functions while analyzing their key characteristics.

8.PFA.1

The student will represent, simplify, and generate equivalent algebraic expressions in one variable.

Students will demonstrate the following Knowledge and Skills:

- Represent algebraic expressions using concrete manipulatives or pictorial representations (e.g., colored chips, algebra tiles), including expressions that apply the distributive property.
- Simplify and generate equivalent algebraic expressions in one variable by applying the order of operations and properties of real numbers. Expressions may need to be expanded (using the distributive property) or require combining like terms to simplify. Expressions will include only linear and numeric terms. Coefficients and numeric terms may be rational.

Understanding the Standard

- The distributive property can be demonstrated by multiplying the sum of two or more addends by a number. The same result can be obtained by multiplying each addend individually by a number and then adding the products.

$$3 \times (2 + 3) = (3 \times 2) + (3 \times 3)$$

- The distributive property is a useful tool for mental math. For example: $7 \cdot 13 = 7(10 + 3) = (10 \cdot 7) + (3 \cdot 7) = 70 + 21 = 91$. Modeling the distributive property should reflect the Concrete-Representational-Abstract (CRA) model.

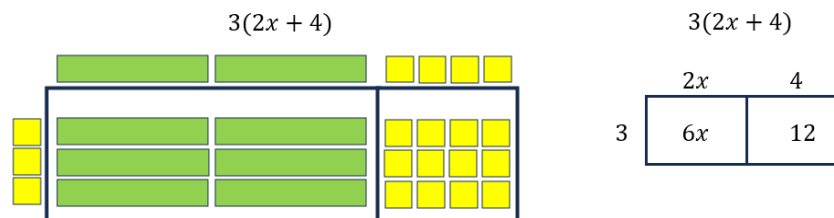

- An expression is a representation of a quantity. It may contain numbers, variables, and/or operation symbols. It does not have an “equal sign” (e.g., $\frac{3}{4}$, $5x$; $140 - 38.2$; $-18 \cdot 21$; $(5 + 2x) \cdot 4$). An expression cannot be solved.
- A numerical expression contains only numbers, the operations symbols, and grouping symbols.
- Expressions are simplified using the order of operations.
- An algebraic expression is a variable expression that contains at least one variable (e.g., $x - 3$).
- Simplifying an algebraic expression means to write the expression as a more compact and equivalent expression. This usually involves combining like terms.
- Like terms are terms that have the same variables and exponents. The coefficients need not be equivalent (e.g., $12x$ and $-5x$; 45 and -5 and $\frac{2}{3}$; $9y$ and $-51y$ and $\frac{4}{9}y$.) Like terms in Grade 8 are limited to variables with an exponent of 1.
- Like terms may be added or subtracted using the distributive and other properties. For example,

$$\begin{aligned} &2(4x - 2) + 3x \\ &8x - 4 + 3x \\ &11x - 4 \end{aligned}$$

- The order of operations is as follows:
 - First, complete all operations within grouping symbols.
 - Parentheses (), brackets [], braces { }, absolute value || and the division bar should be treated as grouping symbols.
 - For example: $|3(-5 + 2)|$; $3(-5 + 2) - 7$; $\frac{3+4}{5+6}$
 - If there are grouping symbols within other grouping symbols, do the innermost operation first.
 - Second, evaluate all terms with exponents.

- Third, multiply and/or divide in order from left to right.
- Fourth, add and/or subtract in order from left to right.
- Properties of real numbers can be used to express simplification. The following properties can be used, where appropriate, to further develop flexibility and fluency in problem solving (limitations may exist for the values of a , b , or c in this standard).
 - Commutative property of addition: $a + b = b + a$.
 - Commutative property of multiplication: $a \cdot b = b \cdot a$.
 - Associative property of addition: $(a + b) + c = a + (b + c)$.
 - Associative property of multiplication: $(a \cdot b) \cdot c = a \cdot (b \cdot c)$.
 - Subtraction and division are neither commutative nor associative.
 - Distributive property (over addition/subtraction): $a(b + c) = a \cdot b + a \cdot c$ and $a(b - c) = a \cdot b - a \cdot c$.
 - The additive identity is zero (0) because any number added to zero is the number.
 - Identity property of addition (additive identity property): $a + 0 = a$ and $0 + a = a$.
 - The multiplicative identity is one (1) because any number multiplied by one is the number.
 - Identity property of multiplication (multiplicative identity property): $a \cdot 1 = a$ and $1 \cdot a = a$.
 - There are no identity elements for subtraction and division.
 - Inverses are numbers that combine with other numbers and result in identity elements (e.g., $5 + (-5) = 0$; $\frac{1}{5} \cdot 5 = 1$).
 - Inverse property of addition (additive inverse property): $a + (-a) = 0$ and $(-a) + a = 0$.
 - Inverse property of multiplication (multiplicative inverse property): $a \cdot \frac{1}{a} = 1$ and $\frac{1}{a} \cdot a = 1$.
 - Zero has no multiplicative inverse.
 - Multiplicative property of zero: $a \cdot 0 = 0$ and $0 \cdot a = 0$.
 - Substitution property: If $a = b$, then b can be substituted for a in any expression, equation, or inequality.
- Division by zero is not a possible mathematical operation. It is undefined. In the example below, there is no single defined number possibility for dividing by 0, since zero multiplied by any number is zero:

$$12 \div 0 = r \rightarrow r \cdot 0 = 12$$

Skills in Practice

While the five process goals are expected to be embedded in each standard, the Skills in Practice highlight the most prevalent process goals in relation to the content presented.

Mathematical Problem Solving:

- Expressions are foundational for algebra as they serve as building blocks for work with equations and functions. Expressions serve as powerful tools for exploring, reasoning about, and representing situations.
- Two or more expressions may be equivalent, even when their symbolic forms differ.
- A relatively small number of symbolic transformations can be applied to expressions to yield equivalent expressions.
- Expressions are simplified using the order of operations and applying the properties of real numbers. Common errors or misconceptions include –
 - Applying the Distributive Property to simplify expressions: Students sometimes multiply the first term in the grouping symbols and not others.
 - Applying the properties to simplify algebraic expressions (Additive Identity and Additive Inverse): Students may get the additive identity and additive inverse properties confused because they both use addition.
 - Applying the properties to simplify algebraic expressions (Multiplicative Identity and Multiplicative Inverse): Students may get the multiplicative identity and multiplicative inverse properties confused because they both use multiplication.
 - Applying the properties to simplify algebraic expressions (Multiplicative Property of Zero and Additive Identity): Students may confuse the multiplicative property of zero and additive identity properties confused because they both have a zero in the expression.

Mathematical Representations: Variables are tools for expressing mathematical ideas clearly and concisely. They have many different meanings, depending on context and purpose. Using variables permits representing and writing expressions whose values are not known or vary under different circumstances. The use of variables is important in studying relationships between varying quantities as well as evaluating expressions using the order of operations.

- For example, when using concrete models and transferring to pictorial representations –

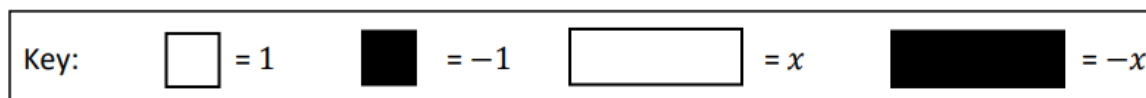

- Draw a model for the expression $2x + 3$: A common error is that some students may incorrectly represent two x as two positive square tiles and one x -tile along with three positive square tiles. Another common mistake is that some students may model two x as two positive square tiles along with three positive square tiles. In either scenario, a student may need more experience modeling single term expressions or numbers before modeling expressions with multiple terms.
- Draw a model for the expression $x - 5$: A student may incorrectly model the expression using only positive tiles, ignoring the negative five. The student may need more experience modeling positive and negative values.

In both of the examples, a student may need opportunities to identify the terms in the expression and model each one separately.

- For example, when evaluating an expression with replacement values using concrete manipulatives:

If given $3x - 2$, model the resulting expression if $x = 3$.

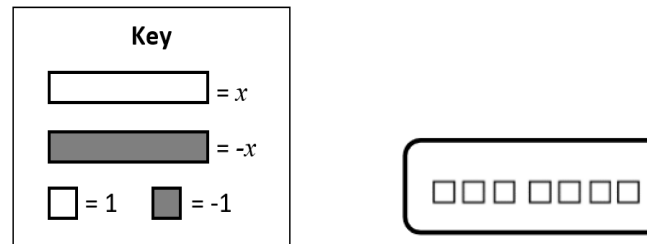

Misinterpreting the sign in a model can cause problems as students continue to model and/or interpret models as they build on expressions to create equations. Discussions regarding the fact that $-x$ is the opposite of x could help these students.

- For example, when simplifying expressions combining like terms, to include rational number coefficients –
 - Simplify the algebraic expression $0.2(d + 10) - 0.9d + 3$: A common error some students will make is to combine like terms incorrectly to get $1.1d$. This may indicate that these students are not recognizing the $0.9d$ as a negative quantity. After distributing, these students could benefit from rewriting the expression as addition and applying the Commutative Property to reorder so that like terms are next to one another. Color-coding positive and negative values could also help make a connection to the modeling of integer operations.
 - Rewrite the expression $(x - 2) - (3 - x)$ as an equivalent expression in its most simplified form: A common error a student may make is obtaining an answer of -5 . This may indicate a student does not understand that -1 needs to be distributed to both terms in the quantity $3 - x$. Students need to recognize that the factor being distributed to the quantity $3 - x$ is negative 1 or that subtracting is the same as adding the opposite, so the expression could be rewritten as $(x - 2) + -1(3 - x)$. Modeling can help with this situation. After students model $x - 2$, they need to recognize that subtracting the quantity $3 - x$ is the same as adding the opposite of the quantity $3 - x$.

- Simplify the algebraic expression $-\frac{2}{3}b + \frac{1}{4}\left(\frac{4}{5}b - \frac{5}{6}\right)$: One common student error occurs when $-\frac{2}{3}b$ and $\frac{1}{5}b$ are not combined to create $-\frac{7}{15}b$. This indicates that these students do not have a conceptual understanding of combining like terms. Help students to recognize that like terms are terms having the same variables and exponents, but they do not need to have the same coefficients. Students will benefit from experiences where the coefficients of like terms and rational numbers are not integers.

Concepts and Connections

CONCEPTS

Proportional relationships can be described, and generalizations can be made using patterns, relations, and functions. Algebraic equations and inequalities can be used to represent and solve real world problems.

CONNECTIONS

- *Within the grade level/course:*
 - 8.PFA.4 – The student will write and solve multistep linear equations in one variable, including problems in context that require the solution of a multistep linear equation in one variable.
 - 8.PFA.5 – The student will create and solve multistep linear inequalities in one variable, including problems in context that require the solution of a multistep linear inequality in one variable.
- *Vertical Progression:*
 - 7.PFA.2 – The student will simplify numerical expressions, simplify and generate equivalent algebraic expressions in one variable, and evaluate algebraic expressions for given replacement values of the variables.
 - A.EO.1 – The student will represent verbal quantitative situations algebraically and evaluate these expressions for given replacement values of the variables.

ACROSS CONTENT AREAS [THEME – GRAPHING]

- *Computer Science:*
 - Coordinate Plane and Graphing concepts include placing and moving objects in a 2D or 3D coordinate system; and graphing algorithms.
- *Physical Science:*
 - PS.2 The student will investigate and understand that matter is composed of atoms. To meet this standard, students are expected to use models to describe atomic structure and relate kinetic molecular theory to particle motion.
 - PS.3 The student will investigate and understand that matter has properties and is conserved in chemical and physical processes. To meet this standard, students are expected to use models to explain densities.

- PS.5 The student will investigate and understand that energy is conserved. To meet this standard, students are expected to use models to explain energy transfer.
- PS.6 The student will investigate and understand that waves are important in the movement of energy. To meet this standard, students are expected to use models to describe wave characteristics and to explain energy transfer and wave interactions.
- PS.7 The student will investigate and understand that electromagnetic radiation has characteristics. To meet this standard, students are expected use models to explain interrelationships in electromagnetic waves and explain how electromagnetic radiation interacts with materials.
- PS.8 The student will investigate and understand that work, force, and motion are related. To meet this standard, students are expected to use models to represent and explain Newton’s laws.
- PS.9 The student will investigate and understand that there are basic principles of electricity and magnetism. To meet this standard, students are expected to use models to explain imbalance of charges, illustrate energy transfer in elective circuits, and explain function of semiconductors.

Resources to Support Local Curriculum

- A list of approved textbooks and instructional materials is posted on the VDOE [website](#).
- [Middle School Mathematics Formula Sheet](#) (PDF)
- Expressions, Expressions, and More Expressions Exemplar Mathematics Instructional Plan ([Word](#) | [PDF](#))

8.PFA.2

The student will determine whether a given relation is a function and determine the domain and range of a function.

Students will demonstrate the following Knowledge and Skills:

- Determine whether a relation, represented by a set of ordered pairs, a table, or a graph of discrete points is a function. Sets are limited to no more than 10 ordered pairs.
- Identify the domain and range of a function represented as a set of ordered pairs, a table, or a graph of discrete points.

Understanding the Standard

- A relation is any set of ordered pairs. For each first member, there may be many second members.
- A function is a relation between a set of inputs, called the domain, and a set of outputs, called the range, with the property that each input is related to exactly one output.
- The domain is the set of all the input values for the independent variable or x -values (first number in an ordered pair).
- The range is the set of all the output values for the dependent variable or y -values (second number in an ordered pair).

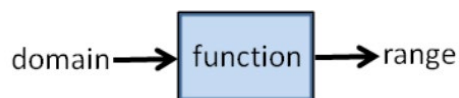

- As a table of values, a function has a unique value assigned to the second variable for each value of the first variable. In the “not a function” example below, the input value “1” has two different output values, 5 and -3 , assigned to it, so the example is not a function.

function		not a function	
x	y	x	y
2	3	2	3
1	5	1	5
0	3	0	4
-1	-3	1	-3

- As a set of ordered pairs, a function has a unique or different y -value assigned to each x -value. For example, the set of ordered pairs, $\{(1, 2), (2, 4), (3, 2), (4, 8)\}$ is a function. However, this set of ordered pairs, $\{(1, 2), (2, 4), (3, 2), (2, 3)\}$, is not a function because the x -value of “2” has two different y -values.
- Some relations are functions; all functions are relations.
- Graphs of functions can be discrete or continuous.

- In a discrete function graph, there are separate, distinct points. A line would not be used to connect these points on a graph. The points between the plotted points have no meaning and cannot be interpreted. For example, the number of pets per household represents a discrete function because it is not possible to have a fraction of a pet.
- not possible to have a fraction of a pet.
- Functions may be represented as ordered pairs, tables, graphs, equations, physical models, or in words. Any given relationship can be represented using multiple representations.
- If a function is comprised of a discrete set of ordered pairs, then the domain is the set of all the x -coordinates, and the range is the set of all the y -coordinates. These sets of values can be determined given different representations of the function. For example, the domain of a function is $\{-1, 1, 2, 3\}$ and the range is $\{-3, 3, 5\}$. The following examples are representations of this function.
 - The function represented as a table of values:

x	y
-1	5
1	-3
2	3
3	5

- The function represented as a set of ordered pairs: $\{(-1, 5), (1, -3), (2, 3), (3, 5)\}$.
- The function represented as a graph on a coordinate plane:

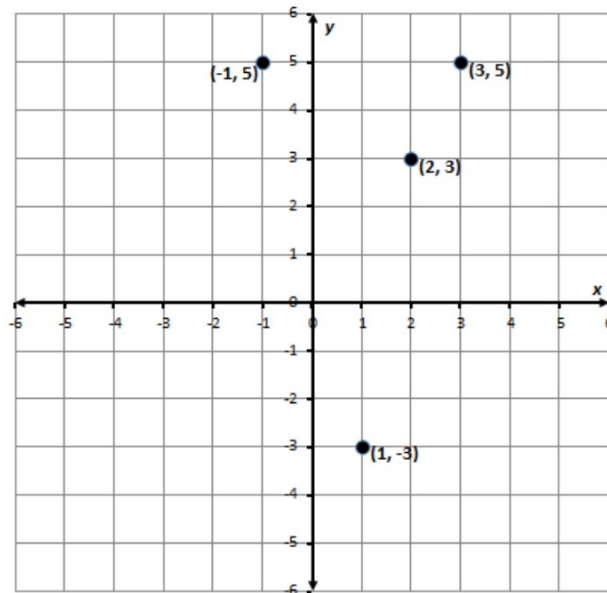

- As a graph of discrete points, a relation is a function when, for any value of x , a vertical line passes through no more than one point on the graph.
- A discussion about determining whether a continuous graph of a relation is a function using the vertical line test may occur in Grade 8 but will be explored further in Algebra 1.

Skills in Practice

While the five process goals are expected to be embedded in each standard, the Skills in Practice highlight the most prevalent process goals in relation to the content presented.

Mathematical Representations and Reasoning: Functions may be represented as ordered pairs, tables, graphs, equations, physical models, or in words. Functions are a relationship between varying quantities – an input (or independent variable) and an output (or dependent variable), with exactly one output for each input. The set of values for the input is its domain and all possible output values is its range. As students determine whether a relation is a function, multiple representations can be used. If a number is repeated in the input or output of the relation, students may incorrectly repeat the number in the domain or range. Students should justify their responses when presented with relations to demonstrate their understanding of the standard. Examples are provided with common misconceptions to follow –

- Does the relation presented in the table represent a function?

x	y
-2	3
-1	3
0	3
1	3
2	3

A common error is for students to say that this relation does not represent a function because of the repeating y -value of 3. This indicates that a student believes that if any y -value repeats then the relation is not a function. These students could benefit from graphing the ordered pairs so they can see the relation represented visually to see that the points are not aligned vertically. These students could also benefit from experimenting with a function machine whose rule is $y = 0x + 3$. Each input, or x -value, has a unique output, or y -value. All output values are the same, 3.

- Does the relation presented in the set of ordered pairs represent a function?

$$\{(-3, 5), (-1, 2), (0, 0), (-1, 6), (-2, 4)\}$$

A common error that students make is declaring that this relation represents a function because they do not recognize that the x -value of “-1” has two different y -values.

- Does the relation presented represent a function?

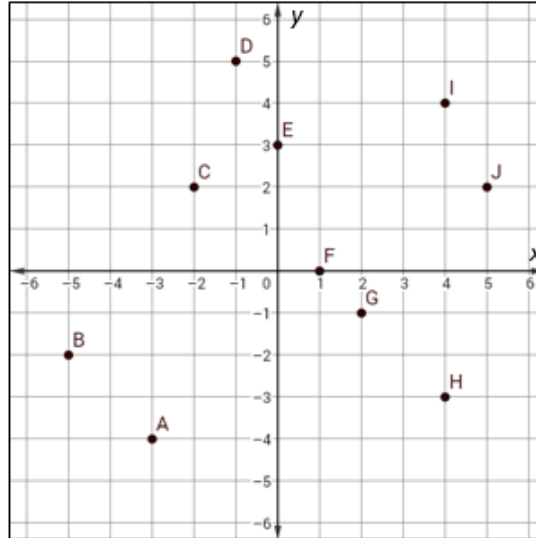

A common error that students make is declaring that this relation represents a function because they do not see a repeating x -value. Students should apply the vertical line test when points are plotted in the coordinate plane to determine whether a function exists. Students may confuse horizontal and vertical direction when applying the vertical line test.

Mathematical Connections:

- Provide students with a function in one form and have them add two additional points, table entries, or ordered pairs so that it remains a function.
- Provide students with a function in one form and have them add one additional point, table entry, or ordered pair so that it is no longer a function.
- Ask students to explain the statement, “*Some relations are functions; all functions are relations,*” and provide an example of each.
- Provide students with additional examples of relations to identify which are functions. With those that are functions, give the domain and range.

Concepts and Connections

CONCEPTS

Proportional relationships can be described, and generalizations can be made using patterns, relations, and functions. Algebraic equations and inequalities can be used to represent and solve real world problems.

CONNECTIONS

- *Within the grade level/course:*
 - 8.PFA.3 – The student will represent and solve problems, including those in context, by using linear functions and analyzing their key characteristics (the value of the y -intercept (b) and the coordinates of the ordered pairs in graphs will be limited to integers).
- *Vertical Progression:*
 - There are no formal standards that address determining whether a given relation is a function or the domain and range of a function in previous grade levels.
 - A.F.1 – The student will investigate, analyze, and compare linear functions algebraically and graphically, and model linear relationships.
 - A.F.2 – The student will investigate, analyze, and compare characteristics of functions, including quadratic and exponential functions, and model quadratic and exponential relationships.

ACROSS CONTENT AREAS

Reference 8.PFA.1

Resources to Support Local Curriculum

- A list of approved textbooks and instructional materials is posted on the VDOE [website](#).
- [Middle School Mathematics Formula Sheet](#) (PDF)

8.PFA.3

The student will represent and solve problems, including those in context, by using linear functions and analyzing their key characteristics (the value of the y -intercept (b) and the coordinates of the ordered pairs in graphs will be limited to integers).

Students will demonstrate the following Knowledge and Skills:

- Determine how adding a constant (b) to the equation of a proportional relationship $y = mx$ will translate the line on a graph.
- Describe key characteristics of linear functions including slope (m), y -intercept (b), and independent and dependent variables.
- Graph a linear function given a table, equation, or a situation in context.
- Create a table of values for a linear function given a graph, equation in the form of $y = mx + b$, or context.
- Write an equation of a linear function in the form $y = mx + b$, given a graph, table, or a situation in context.
- Create a context for a linear function given a graph, table, or equation in the form $y = mx + b$.

Understanding the Standard

- Functions may be a set of discrete points or a continuous set of points. A linear function is an equation in two variables whose graph is a straight line, a type of continuous function.
- A linear function represents a situation with a constant rate. For example, when driving at a steady rate of 35 mph, the distance increases as the time increases, but the rate of speed remains the same.
- Slope (m) represents the rate of change in a linear function or the “steepness” of the line. The slope of a line is a rate of change, a ratio describing the vertical change to the horizontal change.

$$\text{slope} = \frac{\text{change in } y}{\text{change in } x} = \frac{\text{vertical change}}{\text{horizontal change}}$$

- A line is increasing if it rises from left to right. The slope is positive (i.e., $m > 0$).
- A line is decreasing if it falls from left to right. The slope is negative (i.e., $m < 0$).
- A horizontal line has zero slope (i.e., $m = 0$).

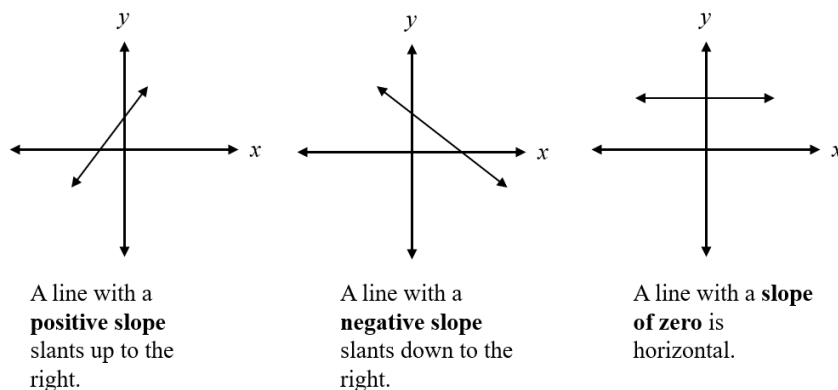

- A discussion about lines with undefined slope (vertical lines) would be beneficial for students in Grade 8 mathematics to compare undefined slope to lines with a defined slope. Further exploration of this concept will occur in Algebra 1.
- A linear function can be written in the form $y = mx + b$, where m represents the slope or rate of change in y compared to x , and b represents the y -intercept of the graph of the linear function. The y -intercept is the point at which the graph of the function intersects the y -axis and may be given as a single value, b , or as the location of a point $(0, b)$.
- The impact of b on $y = mx$ will determine if the line created will translate a parallel line up or down from the origin. The value of b determines where the line will intersect the y -axis. If b is a positive value, the line will translate up on the y -axis; if it is negative, it will translate down on the y -axis.
 - Example: Given the equation of the linear function $y = -3x + 2$, the slope is -3 or $\frac{-3}{1}$ and the y -intercept is 2 or $(0, 2)$.
 - Example: The table of values represents a linear function.

	x	y
+1	-2	8
+1	-1	5
+1	0	2
+1	1	-1
+1	2	-4

In the table, the point $(0, 2)$ represents the y -intercept. The slope is determined by observing the change in each y -value compared to the corresponding change in the x -value.

$$\text{slope} = m = \frac{\text{change in } y\text{-value}}{\text{change in } x\text{-value}} = \frac{-3}{+1} = -3$$

The slope, m , and y -intercept of a linear function can be determined given the graph of the function.

- Example: Given the graph of the linear function, determine the slope and y -intercept.

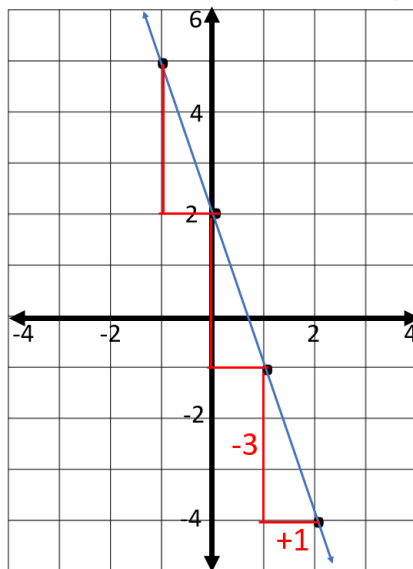

- Given the graph of a linear function, the y -intercept is found by determining where the line intersects the y -axis. The y -intercept would be 2 or located at the point $(0, 2)$. The slope can be found by determining the change in each y -value compared to the change in each x -value. Here, we could use slope triangles to help visualize this:

$$\text{slope} = m = \frac{\text{change in } y\text{-value}}{\text{change in } x\text{-value}} = \frac{-3}{+1} = -3$$

- Graphing a linear function given an equation can be addressed using different methods. One method involves determining a table of ordered pairs by substituting into the equation values for one variable and solving for the other variable, plotting the ordered pairs in the coordinate plane, and connecting the points to form a straight line. Another method involves using slope triangles to determine points on the line. For example, graph the linear function whose equation is $y = 5x - 1$.
 - To graph the linear function, a table of values can be created by substituting arbitrary values for x to determine coordinating values for y :

x	$5x - 1$	y
-1	$5(-1) - 1$	-6
0	$5(0) - 1$	-1
1	$5(1) - 1$	4
2	$5(2) - 1$	9

- The values can then be plotted as points on a graph.
- Knowing the equation of a linear function written in $y = mx + b$ provides information about the slope and y -intercept of the function. If the equation is $y = 5x - 1$, then the slope, m , of the line is 5 or $\frac{5}{1}$, and the y -intercept is -1 and can be located at the point $(0, -1)$. The line can be graphed by first plotting the y -intercept.
- Other points can be plotted on the graph using the relationship between the y and x values.
- Slope triangles can be used to help locate the other points as shown in the graph below.

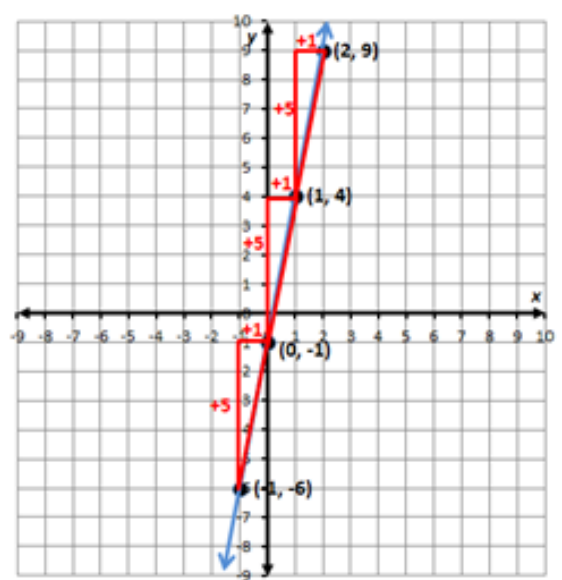

- A table of values can be used in conjunction with slope triangles to verify the graph of a linear function. The y -intercept is located on the y -axis, which is where the x -coordinate is 0. The change in each y -value compared to the corresponding x -value can be verified by the patterns in the table of values.

	x	y	
	-1	-6	+5
+1	0	-1	
+1	1	4	
+1	2	9	+5

- The axes of a coordinate plane are generally labeled x and y ; however, any letters may be used that are appropriate for the function.
- A function has values that represent the input (x) and values that represent the output (y). The independent variable is the input value. The dependent variable depends on the independent variable and is the output value.
- Below is a table of values for finding the approximate circumference of circles, $C = \pi d$, where the value of π is approximated as 3.14.

Diameter	Circumference
1 in.	3.14 in.
2 in.	6.28 in.
3 in.	9.42 in.
4 in.	12.56 in.

- The independent variable, or input, is the diameter of the circle. The values for the diameter make up the domain.
- The dependent variable, or output, is the circumference of the circle. The set of values for the circumference makes up the range.
- In a graph of a continuous function, every point in the domain can be interpreted. Therefore, it is possible to connect the points on the graph with a continuous line because every point on the line answers the original question being asked.
- The context of a problem may determine whether it is appropriate for ordered pairs representing a linear relationship to be connected by a straight line. If the independent variable (x) represents a discrete quantity (e.g., number of people, number of tickets) then it is not appropriate to connect the ordered pairs with a straight line when graphing. If the independent variable (x) represents a continuous quantity (e.g., amount of time, temperature), then it is appropriate to connect the ordered pairs with a straight line when graphing.
 - Example: The function $y = 7x$ represents the cost in dollars (y) for x tickets to an event. The domain of this function is discrete and is represented by discrete points on a graph. Not all values for x could be represented and connecting the points would not be appropriate.
 - Example: The function $y = -2.5x + 20$ represents the number of gallons of water (y) remaining in a 20-gallon tank being drained for x number of minutes. The domain in this function would be continuous. There would be an x -value representing any point in time

until the tank is drained so connecting the points to form a straight line would be appropriate. Note: the context of the problem limits the values that x can represent to positive values, since time cannot be negative.

- Functions can be represented as ordered pairs, tables, graphs, equations, physical models, or in words. Any given relationship can be represented using multiple representations.
- The equation $y = mx + b$ defines a linear function whose graph (solution) is a straight line. The equation of a linear function can be determined given the slope, m , and the y -intercept, b . Verbal descriptions of contextual situations that can be modeled by a linear function can also be represented using an equation.
 - Example: Write the equation of a linear function whose slope is $\frac{3}{4}$ and y -intercept is -4 , or located at the point $(0, -4)$.
 - The equation of this line can be found by substituting the values for the slope, $m = \frac{3}{4}$, and the y -intercept, $b = -4$, into the general form of a linear function $y = mx + b$. Thus, the equation would be $y = \frac{3}{4}x - 4$.
 - Example: A trampoline park charges a flat fee of \$10 and \$3.50 per hour to play. Write a linear function that represents the total cost, y , of playing at the trampoline park, based on the number of hours, x .
 - In this contextual situation, the y -intercept, b , would be \$10 to represent the flat fee. The slope, m , would be \$3.50 since that would represent the rate per hour. The equation to represent this situation would be $y = 3.50x + 10$.
 - Example: John charges a \$30 flat fee to evaluate a personal watercraft that is not working properly and \$50 per hour for any necessary repairs. Write a linear function that represents the total cost, y , of a personal watercraft repair, based on the number of hours, x , needed to repair it. Assume that there is no additional charge for parts.
 - In this contextual situation, the y -intercept, b , would be \$30 to represent the initial flat fee to evaluate the watercraft. The slope, m , would be \$50 since that would represent the rate per hour. The equation to represent this situation would be $y = 50x + 30$.
- A proportional relationship between two variables can be represented by a linear function $y = mx$ that passes through the point $(0, 0)$ and thus has a y -intercept of 0. The variable y results from x being multiplied by m , the rate of change or slope.
- The linear function $y = x + b$ represents a linear function that is a non-proportional additive relationship. The variable y results from the value b being added to x . In this linear relationship, there is a y -intercept of b , and the constant rate of change or slope would be 1. In a linear function with a slope other than 1, there is a coefficient in front of the x term, which represents the constant rate of change, or slope.

Skills in Practice

While the five process goals are expected to be embedded in each standard, the Skills in Practice highlight the most prevalent process goals in relation to the content presented.

Mathematical Reasoning: Functional reasoning builds on counting strategies, additive thinking, multiplicative reasoning, and proportional reasoning. Functional reasoning means that students consider the effect of the rate (which is a ratio - proportional reasoning) on the function, which is (often) a set of infinite points that follow a rule (which often contains additive and multiplicative relationships). Because they are considering two-dimensional points, this means that the student is also considering the effect the domain has on the range as it interacts with the rule. This reasoning helps to form the connections between whether a relation is a function; the domain, range, and transformation of linear functions; and proportionality (rates of change). For example –

What transformations of the graph $y = x$, the equation corresponding to the simplest linear function, are involved in construction graphs for each of the following linear equations? Each function and a graphical representation are provided below.

$$y = 3x \quad y = x - 2 \quad y = -0.5x \quad y = -0.5x + 4$$

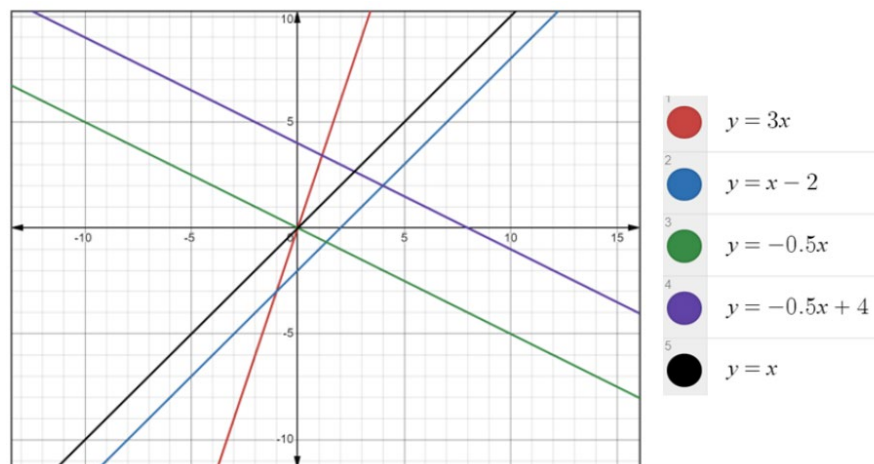

As students examine functions of this type, guide them through examining the steepness of the lines, what transpires between $y = x$ to each of the functions and how the coefficients and the y -intercept impact the line.

Mathematical Connections: Functions provide a tool for describing how variables change together. Using a function in this way is called modeling and the function is called a model. For example, in the rule $y = 5x - 3$, every unit increase in the input, x , corresponds to an increase of 5 in the output, y . When students analyze the way in which one variable changes as the other changes, they can develop an understanding of the pattern of change of the function. Different patterns of change provide a way for students to classify functions into families on the basis of the kinds of mathematical and contextual situations that they can model. For example, at this grade level, linear

functions are characterized by a constant additive increase or decrease – for any unit increase in the input, the output increases (or decreases) by a constant amount.

Mathematical Representations: Functions can be represented in multiple ways – in algebraic symbols, verbal descriptions, graphs, tables, rules, and contextual situations – and these representations help students to analyze patterns of change. Opportunities for students to engage in problems, including those in context, will strengthen their understanding of the concepts presented in this standard. An example with a common misconception follows –

- A landscaper charges each customer a flat rate of \$150 to develop a plan for the landscaping of an outdoor space. The landscaper also charges \$22.50 for each hour of manual labor invested in the landscaping. Write an equation to represent the relationship between the number of hours of manual labor, x , and the total cost, y , for the customer to plan and landscape an outdoor space.

A common error some students may make is to record the equation $y = 150x + 22.50$. This may indicate that the student does not understand that a flat rate represents a one-time charge that appears as the y -intercept in the equation and that an hourly charge is a rate of change that appears as the slope. The student may have also just recorded numbers in the order that they appear in the problem. This student requires additional practice identifying the slope and y -intercept in a practical situation.

Concepts and Connections

CONCEPTS

Proportional relationships can be described, and generalizations can be made using patterns, relations, and functions. Algebraic equations and inequalities can be used to represent and solve real world problems.

CONNECTIONS

- *Within the grade level/course:*
 - 8.PFA.4 – The student will write and solve multistep linear equations in one variable, including problems in context that require the solution of a multistep linear equation in one variable.
 - 8.PFA.5 – The student will create and solve multistep linear inequalities in one variable, including problems in context that require the solution of a multistep linear inequality in one variable.
- *Vertical Progression:*
 - 7.PFA.1 – The student will investigate and analyze proportional relationships between two quantities using verbal descriptions, tables, equations in $y = mx$ form, and graphs, including problems in context.
 - A.F.1 – The student will investigate, analyze, and compare linear functions algebraically and graphically, and model linear relationships.

- A.ST.1g – The students will investigate and explain the meaning of the rate of change (slope) and y-intercept (constant term) of a linear model in context.

ACROSS CONTENT AREAS

Reference 8.PFA.1

Resources to Support Local Curriculum

- A list of approved textbooks and instructional materials is posted on the VDOE [website](#).
- [Middle School Mathematics Formula Sheet](#) (PDF)

8.PFA.4

The student will write and solve multistep linear equations in one variable, including problems in context that require the solution of a multistep linear equation in one variable.

Students will demonstrate the following Knowledge and Skills:

- a) Represent and solve multistep linear equations in one variable with the variable on one or both sides of the equation (up to four steps) using a variety of concrete materials and pictorial representations.
- b) Apply properties of real numbers and properties of equality to solve multistep linear equations in one variable (up to four steps). Coefficients and numeric terms will be rational. Equations may contain expressions that need to be expanded (using the distributive property) or require combining like terms to solve.
- c) Write a multistep linear equation in one variable to represent a verbal situation, including those in context.
- d) Create a verbal situation in context given a multistep linear equation in one variable.
- e) Solve problems in context that require the solution of a multistep linear equation.
- f) Interpret algebraic solutions in context to linear equations in one variable.
- g) Confirm algebraic solutions to linear equations in one variable.

Understanding the Standard

- A linear equation in one variable that does not exceed four steps could include, but are not limited to:
 - $2x + 5 = 4x + 6$
 - $3x + 5 - 6x = 8$
 - $3(x + 5) = 10$
 - $-2(x + 4) + 5x = 6x - 5$
- Equations that result in no solution or infinite solutions are beyond the scope of this standard.
- Modeling linear equations in one variable should reflect the Concrete-Representational-Abstract (CRA) model where the use of concrete materials is followed by pictorial representations, followed by abstract use of properties to solve.
- An algebraic equation is a mathematical statement that says that two expressions are equal (e.g., $2x + 3 = -4x + 1$).
- In an equation, the equal sign (=) indicates that the value of the expression on the left is equivalent to the value of the expression on the right.
- Linear equations can be used to interpret, represent, model, and solve problems in context.
- Word choice and language are very important when representing verbal situations in context using mathematical operations, equality, and variables. When presented with an equation or context, student choice of language should reflect the situation being modeled.

Identifying the mathematical operation(s) to represent the action(s) and the variable to represent the unknown quantity will help students write equations to represent contextual situations.

- At this level, when creating equations and verbal situations in context, the coefficient is limited to a positive value.
- Properties of real numbers and properties of equality can be used to solve equations, justify solutions, and express simplification. The following properties can be used, where appropriate, to further develop flexibility and fluency in problem solving (limitations may exist for the values of a , b , or c in this standard):
 - Commutative property of addition: $a + b = b + a$
 - Commutative property of multiplication: $a \cdot b = b \cdot a$
 - Associative property of addition: $(a + b) + c = a + (b + c)$
 - Associative property of multiplication: $(a \cdot b) \cdot c = a \cdot (b \cdot c)$
 - Subtraction and division are neither commutative nor associative.
 - Distributive property (over addition/subtraction): $a \cdot (b + c) = a \cdot b + a \cdot c$ and $a \cdot (b - c) = a \cdot b - a \cdot c$
 - The additive identity is zero (0) because any number added to zero is the number.
 - Identity property of addition (additive identity property): $a + 0 = a$ and $0 + a = a$
 - The multiplicative identity is one (1) because any number multiplied by one is the number.
 - Identity property of multiplication (multiplicative identity property): $a \cdot 1 = a$ and $1 \cdot a = a$
 - There are no identity elements for subtraction and division.
 - Inverses are numbers that combine with other numbers and result in identity elements (e.g., $5 + (-5) = 0$; $\frac{1}{5} \cdot 5 = 1$).
 - Inverse property of addition (additive inverse property): $a + (-a) = 0$ and $(-a) + a = 0$
 - Inverse property of multiplication (multiplicative inverse property): $a \cdot \frac{1}{a} = 1$ and $\frac{1}{a} \cdot a = 1$
 - Zero has no multiplicative inverse.
 - Multiplicative property of zero: $a \cdot 0 = 0$ and $0 \cdot a = 0$
 - Substitution property: If $a = b$, then b can be substituted for a in any expression, equation, or inequality
 - Addition property of equality: If $a = b$, then $a + c = b + c$
 - Subtraction property of equality: If $a = b$, then $a - c = b - c$
 - Multiplication property of equality: If $a = b$, then $a \cdot c = b \cdot c$
 - Division property of equality: If $a = b$ and $c \neq 0$, then $\frac{a}{c} = \frac{b}{c}$
- Division by zero is not a possible mathematical operation. It is undefined. In the example below, there is no single defined number possibility for dividing by 0, since zero multiplied by any number is zero:

$$12 \div 0 = r \rightarrow r \cdot 0 = 12$$

Skills in Practice

While the five process goals are expected to be embedded in each standard, the Skills in Practice highlight the most prevalent process goals in relation to the content presented.

Mathematical Problem Solving:

- General algorithms exist for solving many kinds of equations. These algorithms are broadly applicable for solving a wide range of similar equations.
- Some problems or situations – circumstances that students explore concretely and immediately (for example, by working with algebra tiles) and circumstances in stated problems – should be based on situations from everyday life.
- Linear equations can be solved by symbolic, graphical, or numerical methods. Students may have trouble moving from solving linear equations using concrete materials to solving linear equations numerically. It is important to link the two methods together before releasing students to solve solely using algebraic methods.
- Students should have an understanding of and be able to apply the properties of real numbers and properties of equality to solve equations. Students should be familiar with the properties of real numbers and properties of equality. Common errors or misconceptions include –
 - Additive inverse and identity: Students may get the additive identity and additive inverse properties confused because they both use addition.
 - Distributive property: Students sometimes multiply the first term in the grouping symbols but not all the others.
 - Multiplicative inverse and identity: Students may get the multiplicative identity and multiplicative inverse properties confused because they both use multiplication.
 - Multiplicative property of zero: Students may confuse the multiplicative property of zero and additive identity properties because they both have a zero in the expression.

Mathematical Reasoning: Teach students to utilize the structure of algebraic representations. Structure refers to an algebraic representation's underlying mathematical features and relationships, such as the number, type, and position of quantities, including variables; the number, type, and position of operations; the presence of an equality; the relationships between quantities, operations, and equalities; the range of complexity among expressions, with simpler expressions nested inside more complex ones.

Paying attention to structure helps students make connections among problems, solution strategies, and representations that may initially appear different but are actually mathematically similar. Consider these three equations –

$$2x + 8 = 14$$

$$2(x + 1) + 8 = 14$$

$$2(3x + 4) + 8 = 14$$

Though the equations appear different, they have similar structures. In all three equations, **2 multiplied by a quantity, plus 8**, equals 14. With an understanding of structure, students can focus on the mathematical similarities of problems that may appear to be different, which can simplify solving algebra problems. In particular, recognizing structure helps students understand the characteristics of algebraic expressions and problems regardless of whether the problems are presented in symbolic, numeric, verbal, or graphic forms.

Mathematical Communication: Encourage students to use reflective questioning to notice structure as they solve problems. By asking themselves questions about a problem they are solving, students can think about the structure of the problem and the potential strategies they could use to solve the problem. First, model reflective questioning to students by thinking aloud while solving a problem. Teachers can write down the questions they ask themselves to clearly demonstrate the steps of their thinking processes. Then, present a problem during whole-class instruction, and ask students to write down what questions they might ask themselves to solve the problem. Students can practice the think-aloud process while working in pairs or share their written ideas with a partner. This process will help students use reflective questioning on their own during independent practice to explore algebraic structure.

Mathematical Representations: Variables are tools for expressing mathematical ideas clearly and concisely. They have many different meanings, depending on context and purpose. Using variables permits representing and writing expressions whose values are not known or vary under different circumstances. This use of variables is important in studying relationships between varying quantities as well as evaluating expressions using the order of operations. Representations of equations with common misconceptions are provided below –

- Find the value of x in the model.

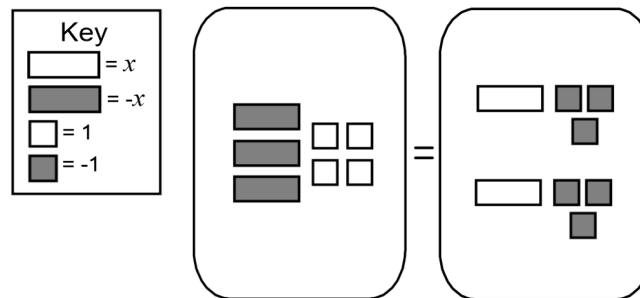

A common error for students is to neglect to discriminate between the positive and negative tiles in a model. This indicates that the student may not have a strong conceptual understanding of the effect a sign error can make. Students will benefit from practicing recording work algebraically as they work through examples using manipulatives.

- Solve for x : $10 - \frac{2}{3}(3x - 12) = 2$

A common error a student may make is inappropriately applying the Distributive Property when simplifying the left side of the equation. A student may neglect to distribute $-\frac{2}{3}$ to the constant in the parentheses, resulting in $10 - 2x - 12 = 2$ and obtaining a solution of $x = -2$. A student may also record “10 – “and only distribute a $\frac{2}{3}$, resulting in the equation $10 - 2x - 8 = 2$ and obtaining a solution of $x = 0$. This implies that the student does not have a strong conceptual understanding of the Distributive Property.

- Jack has \$37 and saves \$6.50 per week. Diane has \$9 and saves \$8.25 per week. Write and solve an equation to find out how many weeks it would take for Jack and Diane to have saved the same amount of money.

A common error a student may make is failing to recognize that the equations should be set equal to each other and try to solve them independently. This would imply that a student may not understand within the context that determining the number of weeks to have saved the same amount of money requires two expressions to be set equal to each other. A more specific error that a student may make is to think Diane needs to save \$28 to reach the \$37 that Jack has and then consequently determine that it would take Diane approximately 3.4 weeks to save the \$28 since she saves \$8.25 per week. This may indicate that students are having difficulty conceptualizing the scenario. Students may benefit from approaching the problem more visually by using a graph or number line to record the initial amount and weekly increments as shown below and by substituting their results into each equation to verify their results.

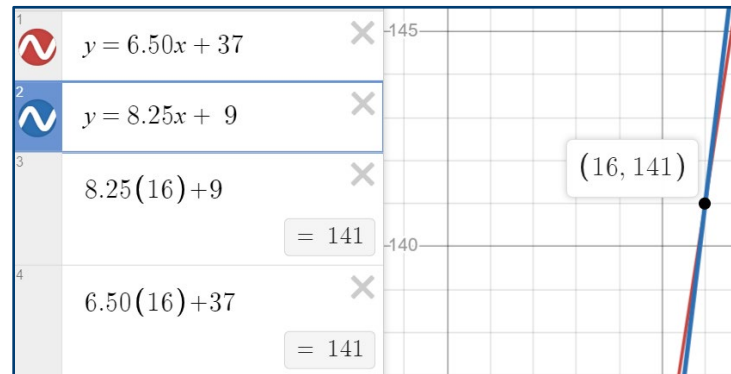

- Janice was asked to solve the equation $2x - 4 = 2(-5x + 1)$. She believes the solution to the equation is $x = \frac{1}{2}$. Explain how Janice could confirm that her solution is correct.

A common error students may make is to confirm the solution by solving the equation a second time. This may indicate that students may not understand that a solution to an equation is a value that makes the statement true. Students may benefit from opportunities to verify solutions to equations using substitution to determine if the value makes the equation true.

- For example, conducting side-by-side comparisons using two different solution strategies –

Strategy 1: Dillan’s Solution – Apply Distributive Property First

Solution Steps:

$$10(y + 2) = 6(y + 2) + 16$$

$$10y + 20 = 6y + 12 + 16$$

$$10y + 20 = 6y + 28$$

$$4y + 20 = 28$$

$$4y = 8$$

$$y = 2$$

Labeled Steps:

Distribute

Combine like terms

Subtract 6y from both sides

Subtract 20 from both sides

Divide by 4 on both sides

Strategy 2: Alexa’s Solution – Collect Like Terms First

Solution Steps:

$$10(y + 2) = 6(y + 2) + 16$$

$$4(y + 2) = 16$$

$$y + 2 = 4$$

$$y = 2$$

Labeled Steps:

Subtract 6(y + 2) on both sides

Divide by 4 on both sides

Subtract 2 from both sides

Provide the class work from past or current students to demonstrate examples of students using multiple strategies. Before introducing a new strategy, provide enough time to practice the strategies students already know and ensure they understand. After they are introduced to different strategies, help them develop skills for selecting the strategy that works best for them. After students find a solution to a problem, challenge them to solve the problem in another way and to generate strategies during group work and/or independent practice time. The following questions may be used when examining problems, strategies, and solutions –

- What similarities do you notice? What differences do you notice?
- To solve this problem, what did each person do first? Is that valid mathematically? Was that useful in this problem?
- What connections do you see between the two examples?
- How was Dillon reasoning through the problem? How was Alexa reasoning through the problem?
- What were they doing differently? How was their reasoning similar?
- Did they both get the correct solution?

- Will Dillon’s strategy always work? What about Alexa’s? Is there another reasonable strategy?
- Which strategy do you prefer? Why?

Concepts and Connections

CONCEPTS

Proportional relationships can be described, and generalizations can be made using patterns, relations, and functions. Algebraic equations and inequalities can be used to represent and solve real world problems.

CONNECTIONS

- *Within the grade level/course:*
 - 8.PFA.1 – The student will represent, simplify, and generate equivalent algebraic expressions in one variable.
 - 8.PFA.5 – The student will create and solve multistep linear inequalities in one variable, including problems in context that require the solution of a multistep linear inequality in one variable.
- *Vertical Progression:*
 - 7.PFA.2 – The student will simplify numerical expressions, simplify and generate equivalent algebraic expressions in one variable, and evaluate algebraic expressions for given replacement values of the variables.
 - 7.PFA.3 – The student will write and solve two-step linear equations in one variable, including problems in context, that require the solution of a two-step linear equation in one variable.
 - 7.PFA.4 – The student will write and solve one- and two-step linear inequalities in one variable, including problems in context, that require the solution of a one- and two-step linear inequality in one variable.
 - A.EO.1 – The student will represent verbal quantitative situations algebraically and evaluate these expressions for given replacement values of the variables.
 - A.EI.1 – The student will represent, solve, explain, and interpret the solution to multistep **linear equations** and inequalities in one variable and **literal equations** for a specified variable.
 - A.EI.2 – The student will represent, solve, explain, and interpret the solution to a **system of two linear equations**, a linear inequality in two variables, or a system of two linear inequalities in two variables.
 - A.EI.3 – The student will represent, solve, and interpret the solution to a **quadratic equation** in one variable.

ACROSS CONTENT AREAS

Reference 8.PFA.1

Resources to Support Local Curriculum

- A list of approved textbooks and instructional materials is posted on the VDOE [website](#).
- [Middle School Mathematics Formula Sheet](#) (PDF)

8.PFA.5

The student will write and solve multistep linear inequalities in one variable, including problems in context that require the solution of a multistep linear inequality in one variable.

Students will demonstrate the following Knowledge and Skills:

- a) Apply properties of real numbers and properties of inequality to solve multistep linear inequalities (up to four steps) in one variable with the variable on one or both sides of the inequality. Coefficients and numeric terms will be rational. Inequalities may contain expressions that need to be expanded (using the distributive property) or require combining like terms to solve.
- b) Represent solutions to inequalities algebraically and graphically using a number line.
- c) Write multistep linear inequalities in one variable to represent a verbal situation, including those in context.
- d) Create a verbal situation in context given a multistep linear inequality in one variable.
- e) Solve problems in context that require the solution of a multistep linear inequality in one variable.
- f) Identify a numerical value(s) that is part of the solution set of a given inequality.
- g) Interpret algebraic solutions in context to linear inequalities in one variable.

Understanding the Standard

- A linear inequality in one variable that does not exceed four steps could include:
 - $2x + 5 < 4x + 6$
 - $3x + 5 - 6x > 8$
 - $3(x + 5) < 10$
- When both expressions of an inequality are multiplied or divided by a negative number, the inequality sign reverses.
- A solution to an inequality is the value or set of values that can be substituted to make the inequality true.
- In an inequality, there can be more than one value for the variable that makes the inequality true. There can be many solutions (e.g., When given the inequality $x + 4 > -3$, the solutions are $x > -7$. This means that x can be any number greater than -7 . A few solutions might be $-6.5, -3, 0, 4, 25$, etc.).
- Real-world problems can be modeled and solved using linear inequalities.
- Word choice and language are very important when representing verbal situations in context using mathematical operations, inequality symbols, and variables. When presented with an inequality or context, student choice of language should reflect the situation being modeled. Identifying the mathematical operation(s) to represent the action(s) and the variable to represent the unknown quantity will help students to write inequalities to represent contextual situations.
- At this level, when creating inequalities and verbal situations in context, the coefficient is limited to a positive value.

- The properties of real numbers and properties of inequality can be used to solve inequalities, justify solutions, and express simplification. Use the following properties, where appropriate, to further develop flexibility and fluency in problem solving (limitations may exist for the values of a , b , or c in this standard).
 - Commutative property of addition: $a + b = b + a$
 - Commutative property of multiplication: $a \cdot b = b \cdot a$
 - Associative property of addition: $(a + b) + c = a + (b + c)$
 - Associative property of multiplication: $(a \cdot b) \cdot c = a \cdot (b \cdot c)$
 - Subtraction and division are neither commutative nor associative.
 - Distributive property (over addition/subtraction): $a \cdot (b + c) = a \cdot b + a \cdot c$ and $a \cdot (b - c) = a \cdot b - a \cdot c$
 - The additive identity is zero (0) because any number added to zero is the number.
 - Identity property of addition (additive identity property): $a + 0 = a$ and $0 + a = a$
 - The multiplicative identity is one (1) because any number multiplied by one is the number.
 - Identity property of multiplication (multiplicative identity property): $a \cdot 1 = a$ and $1 \cdot a = a$
 - There are no identity elements for subtraction and division.
 - Inverses are numbers that combine with other numbers and result in identity elements (e.g., $5 + (-5) = 0$; $\frac{1}{5} \cdot 5 = 1$).
 - Inverse property of addition (additive inverse property): $a + (-a) = 0$ and $(-a) + a = 0$
 - Inverse property of multiplication (multiplicative inverse property): $a \cdot \frac{1}{a} = 1$ and $\frac{1}{a} \cdot a = 1$
 - Zero has no multiplicative inverse.
 - Multiplicative property of zero: $a \cdot 0 = 0$ and $0 \cdot a = 0$.
 - Substitution property: If $a = b$, then b can be substituted for a in any expression, equation, or inequality
 - Addition property of inequality: If $a < b$, then $a + c < b + c$; if $a > b$, then $a + c > b + c$
 - Subtraction property of inequality: If $a < b$, then $a - c < b - c$; if $a > b$, then $a - c > b - c$
 - Multiplication property of inequality: If $a < b$ and $c > 0$, then $a \cdot c < b \cdot c$; if $a > b$ and $c > 0$, then $a \cdot c > b \cdot c$
 - Multiplication property of inequality (multiplication by a negative number): If $a < b$ and $c < 0$, then $a \cdot c > b \cdot c$; if $a > b$ and $c < 0$, then $a \cdot c < b \cdot c$
 - Division property of inequality: If $a < b$ and $c > 0$, then $\frac{a}{c} < \frac{b}{c}$; if $a > b$ and $c > 0$, then $\frac{a}{c} > \frac{b}{c}$
 - Division property of inequality (division by a negative number): If $a < b$ and $c < 0$, then $\frac{a}{c} > \frac{b}{c}$; if $a > b$ and $c < 0$, then $\frac{a}{c} < \frac{b}{c}$
- Division by zero is not a possible mathematical operation. It is undefined. In the example below, there is no single defined number possibility for dividing by 0, since zero multiplied by any number is zero:

$$12 \div 0 = r \rightarrow r \cdot 0 = 12$$

Skills in Practice

While the five process goals are expected to be embedded in each standard, the Skills in Practice highlight the most prevalent process goals in relation to the content presented.

Mathematical Problem Solving: Students must understand that an equation states that two expressions are equal, while an inequality relates two different values. An inequality is another way to describe a relationship between two expressions; instead of showing that the values of two expressions are equal, inequalities indicate that the value of one expression is greater than (or greater than or equal to) the value of the other expression.

- When solving an inequality, multiplying or dividing both expressions by a negative number reverses the sign ($<$, $>$, \leq , \geq) that indicates the relationship between the two expressions. As a strategy, review how to solve one and two-step inequalities. Discuss how the steps for solving inequalities are the same as they are for solving equations, with the exception of one situation: when multiplying or dividing both sides of the inequality by a negative. Review this concept with the following questions and discussion:
 - $4 < 8$. Is this true? YES
 - Add 2 to both sides (now $6 < 10$). Is it still true? YES
 - Subtract 2 from both sides (now $2 < 6$). Is it still true? YES
 - Subtract 9 from both sides (now $-5 < -1$). Is it still true? YES
 - Multiply by 3 on both sides. (now $12 < 24$). Is it still true? YES
 - Multiply by $\frac{1}{2}$ on both sides (now $2 < 4$). Is it still true? YES
 - Divide by 4 on both sides (now $1 < 2$). Is it still true? YES
 - Multiply by -5 on both sides. (now $-20 < -40$). Is it still true? NO
 - Divide by -2 on both sides, (now $-2 < -4$). Is it still true? NO
 - Based on our discussion, can you create a rule about multiplying and dividing by negatives?
- Students must review and apply the properties of real numbers and properties of inequality to solve inequalities. Students should be familiar with the properties of real numbers and properties of equality. Common errors or misconceptions include –
 - **Additive inverse and identity:** Students may get the additive identity and additive inverse properties confused because they both use addition.
 - **Distributive property:** Students sometimes multiply the first term in the grouping symbols and not others.
 - **Multiplicative inverse and identity:** Students may get the multiplicative identity and multiplicative inverse properties confused because they both use multiplication.
 - **Multiplicative property of zero:** Students may confuse the multiplicative property of zero and additive identity properties confused because they both have a zero in the expression.

Mathematical Reasoning: Teach students to utilize the structure of algebraic representations. Structure refers to an algebraic representation’s underlying mathematical features and relationships, such as the number, type, and position of quantities, including variables; the number, type, and position of operations; the presence of an inequality; the relationships between quantities, operations, and inequalities; the range of complexity among expressions, with simpler expressions nested inside more complex ones. Paying attention to structure helps students make connections among problems, solution strategies, and representations that may initially appear different but are actually mathematically similar. Consider these three inequalities –

$$\begin{aligned}2x + 8 &> 14 \\2(x + 1) + 8 &> 14 \\2(3x + 4) + 8 &> 14\end{aligned}$$

Though the inequalities appear different, they have similar structures. In all three inequalities, **2 multiplied by a quantity, plus 8**, is greater than 14. With an understanding of structure, students can focus on the mathematical similarities of problems that may appear to be different, which can simplify solving algebra problems. In particular, recognizing structure helps students understand the characteristics of algebraic expressions and problems regardless of whether the problems are presented in symbolic, numeric, verbal, or graphic forms.

Mathematical Communication: Encourage students to use reflective questioning to notice structure as they solve problems. By asking themselves questions about a problem they are solving, students can think about the structure of the problem and the potential strategies they could use to solve the problem. First, model reflective questioning to students by thinking aloud while solving a problem. Teachers can write down the questions they ask themselves to clearly demonstrate the steps of their thinking processes. Then, present a problem during whole-class instruction, and ask students to write down what questions they might ask themselves to solve the problem. Students can practice the think-aloud process while working in pairs or share their written ideas with a partner. This process will help students use reflective questioning on their own during independent practice to explore algebraic structure.

Mathematical Representations: Students have difficulty understanding, writing, and graphing the inequality both ways (e.g., $m > 6$, $6 < m$). Students have trouble making sense of such terms as “at least” and “at most.” Students use “tricks” to help them figure out which direction to shade the number line without conceptually understanding the meaning of the inequality. Examples with misconceptions are included below -

- Solve the inequality and graph the solution set on the number line.

$$5x - (x - 2) > 14$$

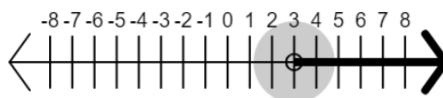

A common error a student may make is not distributing the negative sign to both terms in the expression, $(x - 2)$, resulting in simplified statement of $x > 4$. This may indicate that a student does not have a conceptual understanding that -1 is being multiplied to both terms of the expression $(x - 2)$.

Solve the inequality and graph the solution set on the number line.

$$22 \geq 5(x - 2) + 3x$$



A common error students may make is graphing the simplified inequality of $4 \geq x$ in the wrong direction. This may indicate that students do not understand how to write an equivalent inequality statement with the variable on the left side of the inequality symbol. These students may benefit from writing inequalities in two different ways when presented with a graph of a solution set (e.g., $4 \geq x$ and $x \leq 4$). These students could benefit from recognizing that the original statement can be written as an equivalent statement with the variables on the left side before simplifying. In addition, students could benefit from more experiences graphing inequalities when the variable is on the right side of the inequality symbol.

- Ask students what you need to do when graphing inequalities. They should remember to shade toward the side of the possible solutions and add an arrow. Review how to solve this inequality: $2(x - 3) < 12$. The solution is $x < 9$ and the final graph should look like this:

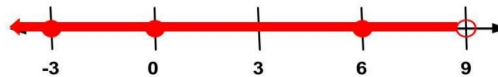

Students should then check to see whether their answers are correct by using the substitution property. If they say that 5 is a possible solution, rewrite the inequality $2(x - 3) < 12$ and substitute 5 for x . Rewrite it as $2((5) - 3) < 12$, solve it, and see whether the statement is true. In this case, 4 is less than 12, so 4 is a correct solution. Accept a variety of responses from the students and try each of them in the same manner.

- Virginia County Marching Band is selling candy bars for a fundraiser. Jeremiah sold some candy bars. Brittney sold twice as many candy bars as Jeremiah. Together Jeremiah and Brittney sold no less than 45 candy bars. Write a multistep linear inequality to represent this situation. Provide at least three possible solutions for how many candy bars Jeremiah sold.

A common error students make is to represent this situation as $x + 2x < 45$. This may indicate that students are interpreting “no less than” as “less than” and using the $<$ symbol. Students may benefit from additional practice translating inequalities where a variety of phrases are used to represent inequality symbols. Students should verify their solutions using a number line.

Concepts and Connections

CONCEPTS

Proportional relationships can be described, and generalizations can be made using patterns, relations, and functions. Algebraic equations and inequalities can be used to represent and solve real world problems.

CONNECTIONS

- *Within the grade level/course:*
 - 8.PFA.1 – The student will represent, simplify, and generate equivalent algebraic expressions in one variable.
 - 8.PFA.4 – The student will write and solve multistep linear equations in one variable, including problems in context that require the solution of a multistep linear equation in one variable.
- *Vertical Progression:*
 - 7.PFA.2 – The student will simplify numerical expressions, simplify and generate equivalent algebraic expressions in one variable, and evaluate algebraic expressions for given replacement values of the variables.
 - 7.PFA.3 – The student will write and solve two-step linear equations in one variable, including problems in context, that require the solution of a two-step linear equation in one variable.
 - 7.PFA.4 – The student will write and solve one- and two-step linear inequalities in one variable, including problems in context, that require the solution of a one- and two-step linear inequality in one variable.
 - A.EO.1 – The student will represent verbal quantitative situations algebraically and evaluate these expressions for given replacement values of the variables.
 - A.EI.1 – The student will represent, solve, explain, and interpret the solution to multistep linear equations and **inequalities** in one variable and literal equations for a specified variable.
 - A.EI.2 – The student will represent, solve, explain, and interpret the solution to a system of two linear equations, a **linear inequality in two variables, or a system of two linear inequalities in two variables**.

ACROSS CONTENT AREAS

Reference 8.PFA.1

Resources to Support Local Curriculum

- A list of approved textbooks and instructional materials is posted on the VDOE [website](#).
- [Middle School Mathematics Formula Sheet](#) (PDF)